

THERMOCODE SERIES 2

OPERATOR INSTRUCTIONS
CIRCUIT DIAGRAMS
INSTALLATION DETAILS

Continuous “53CR” Left Hand Thermal Transfer Printer

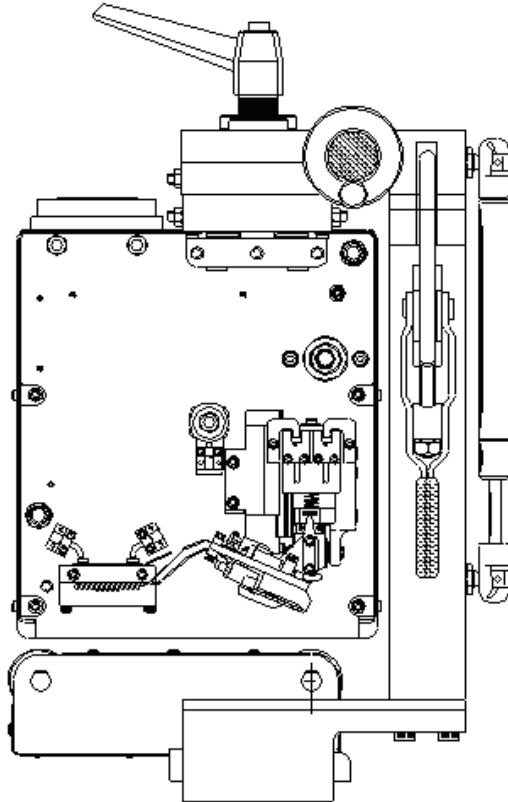

Designed and manufactured by: -

OPEN DATE EQUIPMENT LIMITED

**Units 8 & 9 Puma Trade Park
145 Morden Road
Mitcham
Surrey CR4 4DG**

UNITED KINGDOM

TEL: - 0044 (0) 20 8655 4999

FAX: - 0044 (0) 20 8655 4990

Web Site: - <http://www.opendate.co.uk/>

Technical website: - <http://www.opendateinfo.com/>

Email: - sales@opendate.co.uk

EC DECLARATION OF CONFORMITY

We hereby declare that the following machinery complies with the essential health and safety requirements of the Machinery Directive 89/392/EEC enacted in the United Kingdom by the Supply of Machinery (Safety) Regulations 1992. Amended 1999 (URN 99/1232) Amended 2005

Machine Description: **Thermal Transfer Printer.** Model:

Type: **Thermocode Series 2** Serial Number:

Manufactured by: **Open Date Equipment Limited.
Units 8 & 9 Puma Trade Park,
145 Morden Road,
Mitcham,
Surrey. CR4 4DG
England**

Telephone: - 0208 655 4999

This machinery has been and manufactured in accordance with the following transposed harmonised European standards.

EN ISO 12100: parts 1 and 2, 2003. Safety of Machinery - Basic concepts, principles of design.

EN 294: 1992. Safety of Machinery - Safety distance to prevent danger zones being reached by the upper limb

EN 60204: part 1, 1996. Safety of Machinery - Electrical equipment of machines - Specification for safety requirements.

EN 61000 – 6 – 2: 1999. Electromagnetic compatibility - Generic immunity standard.

EN 61000 – 6 – 3: 2001 Electromagnetic compatibility - Generic emission standard.
(IEC 61000-6-2: 1999,modified)

EN 61000: 3 - 2, 2001. Harmonic Emissions.

EN 61000: part 3 – 3, 1995. Voltage Flicker.

FCC Part 15, Conducted & Radiated Emissions, Class A.

In addition, this machinery has been designed and manufactured in accordance with British Standard **PD 5304: 2005**, Safety of Machinery.

A technical construction file for this machinery is retained at the above address.

Signed: _____ Date: _____

Name: _____ Position: _____

Being the responsible person appointed by Open Date Equipment Limited.

This Declaration of Conformity complies with Regulation 22 of The Supply of Machinery (Safety) Regulations 1992 Amended 1999 (URN 99/1232)

<u>Index</u>	<u>Page No.</u>
This Page	3
Standard Warranty Terms and conditions	4
Safety Instructions.	5
Introduction.	6
System Overview.	6
Optional Extras.	6
Printer Technical Information	6
Installation Procedures	7 - 10
Setting the Five Volts	11
Control Relays	12
Power Supply (I/O Board connections)	13
Power Supply (PNP / NPN Sensors & Volt Free print signals)	14
Power Supply (fuse details etc)	15
Power Supply (LED details)	16
Encoder Description	17
Encoder & Lower Roller Unit, Power Supply Wiring Connections	18
Encoder Types and Wiring Connections	19
System Start Up Sequence	20 - 21
Mini-Terminal Key Mapping	22
Mini Terminal Flow Charts	23 - 29
Quick Selection Reference Sheets	30 - 32
Thermal Ribbon Specification	33
Threading Diagram	34
Cleaning	35 - 36
Fault Finding.	37 - 40
Ribbon Not Indexing Enough, Ribbon Indexing Excessive	37
Ribbon Breaking or Perforated, Ribbon Tracking.	37 - 39
Print Quality Problems	39
Clearing Printer Error Messages	39
Thermocode Diagnostics Sheet 1	40
Thermocode Diagnostics Sheet 2	40
Error Codes	41 -48
Automatic Burn Compensation As Speed Changes	49
Magazine Spares	50
Dimensions	
Printer Dimensions	51
Standard Frame Dimensions	52
Lower Roller Unit Dimensions	53
Power Supply (Dimensional and Installation Details)	54
Computer Connection leads.	55
Airborne Noise Emissions	55
Open Date Group Companies Addresses	56

Standard Warranty Terms and Conditions – Thermocode Series 2 Printers

Open Date thermal transfer printers carry a twelve (12) month return to base (at our discretion) warranty, with the exception of the following parts: -

1. Thermal Printhead.
2. Lower Roller. (Rubber covered Roller)
3. Cassette Springs and Belts.
4. Cassette Rubber Drive Roller.

Static Electricity

Warning, static electricity may damage the printer or printhead. On many film type installations, the material produces static electricity and possibly causes printer problems or printhead failure. Open Date does not accept any type of warranty claims, if any damage to the printer or Printhead is caused by static electricity.

If you are in doubt about your installation, please contact our service department.

Printhead Warranty

The Printhead assembly (ASY762199, ASY762200, ASY762345 or ASY762346) carries a 50 kilometres or 12 months warranty whichever is the soonest. Should the Printhead fail during this period, the replacement Printhead will carry the balance of the existing warranty.

Please refer to the ribbon specifications sheet on page 33, check the correct width of thermal transfer ribbon is being used and has the appropriate silicone back coating to protect the Printhead.

The Printhead warranty will not be valid if: -

1. The full width ribbon is not being used, as excessive wear on the edges of the Printhead can be found. (See page 33)
2. Mechanical damage is apparent from abuse.
3. The Spy Chip Board has been removed or damaged in any way.
4. Cleaning Procedures have not been followed. (See pages 35 & 36)
5. Installation and maintenance procedures are not correct. (See pages 6 – 10)
6. The print base used (Lower roller unit) or roller is not as specified. (See page 53)
7. The Printhead angle has not been set up correctly. (See page 7 – 10)
8. Static Electricity is found.
9. Recommended Open Date ribbon is not being used. (See page 33 Ribbon Specifications)
10. Printing substrate or ribbon is found to be abrasive.

The print base or lower roller assembly carries no warranty, as it is considered to be a consumable item.

We reserve the right to charge for components replaced during the warranty period, which are found damaged due to any of the above conditions not being followed or met.

Printhead Spy Chip

Contained within the Printhead assembly, is a small microchip this is programmed when the head is first assembled and tested to retain the following information: -

1. Printhead resistance value (ohms).
2. Printhead width (Dots).
3. Printhead serial number.
4. Printhead data lines.
5. Programmed factory date.
6. Printhead angle.

During start up of the printer, the Spy Chip is accessed by the software, determining the width of printhead and automatically adjusts the resistance value to compensate for the correct print burn calculations. Whilst printing, the spy chip is written to, allowing automatic recording of the print distance achieved during the life of the printhead.

All the Printhead recorded settings may be viewed at any time, by accessing the Service menu on the mini-terminal Display.

IMPORTANT SAFETY INSTRUCTIONS

1. Read these instructions carefully. Follow all warnings and instructions marked on the product.
2. Always disconnect the printer and Power Supply from the mains electrical supply before attempting to clean or service the product.
3. Never operate the printer, unless it is installed within the mounting frame supplied. When installed correctly, the gap between the printer and print base should be nominally 1mm.
4. Do not use the product near water. Never spill liquid of any kind on to the product.
5. Do not place this product on an unstable stand, table or machine. It may fall causing serious injury to the operator or damage to the product.
6. Never insert objects of any kind into this product through any openings or gaps as they may touch dangerous voltage points or short circuit parts that could result in fire or electric shock.
7. This product should only be connected to the type of electrical supply as indicated on the label located on the top of the Power Supply. (See CE label)
8. Ensure that the printer connection cable is fully secured to the printer and power supply with the screws supplied. Failure to do this will result in the machine not being properly earthed.
9. Use only the power cable supplied with the product. The cable supplied is three core, utilising one wire as a grounding conductor. This must be connected to a suitable earth point at the electrical supply. This is a safety feature. If any doubt arises in trying to connect the power cable, please contact the manufacturer or the agent who supplied the product.
10. Do not allow anything to rest on the power cable. Do not locate the product where people could walk on the cable.
11. If an extension cable is used with this product, make sure that the total ampere ratings of the equipment plugged into the extension cable does not exceed the extension cable ampere rating. Also make sure that the total rating does not exceed the fuse rating.
12. Do not service this product yourself as opening or removing guards may expose you to dangerous voltages, major burns and other risks. Refer all servicing to qualified personnel.
13. Do not attempt to use to use this product in areas where explosive gases or substances are present.
14. Under the following conditions always disconnect the electrical supply and refer to a qualified service engineer.
 - a. If the power cable is damaged or frayed.
 - b. If the printer connection cables are damaged in any way.
 - c. If liquid has been spilled into the product has been exposed to water.
 - d. If the product does not operate normally when the operating instructions are followed.
15. Adjust only those controls covered by these instructions. Improper adjustment could result in permanent damage, requiring qualified technicians to restore the product to normal operating conditions.
16. Do not touch the printer or control box with wet or moist hands.
17. Do not use the Printer without Thermal Transfer Ribbon, as the printhead maybe damaged.

Introduction

This operator manual describes how to operate and maintain a **Thermocode Series 2 (Model 53CR)** on a basic level. The mechanical adjustments that can be made to the printer are minimal. Normally the printer is installed in a standard frame, which allows the correct clearance from the lower roller unit and the alignments deemed needed.

Operation of the printer is either by selection of a stored format within the printer memory, or by designing a dedicated format from the windows software and then downloading from a standalone computer.

Using the mini-terminal, formats can then be selected and edited by the operator as required.

If you are making your own frame or installing into a specific type of machine, you must consult the manufacturer to ensure you receive the correct detailed dimensions required for your installation.

SYSTEM OVERVIEW

The following components are supplied ready for installation.

- 1 Thermocode Model 53CR
- 1 Power Supply Unit (240 Volt or 110 Volt) Selectable inside the unit
- 1 Mini-Terminal display
- 1 Power Supply Interconnection Lead 1.5 metres long
(Available in 3, 5 or 6 metre lengths see page 11)
- 1 Roll of Thermal Transfer Ribbon (300 metres x 55 wide, Wax Resin quality)
- 1 Operator Manual
- 1 Printhead Cleaning Kit, Consisting off 50 Print head Cleaning Wipes (Isopropyl Alcohol)
- 1 Programming lead (3 Metre length, 9 way "D" connector)
- 1 Recover Mode software backup program (Allows customer to back up all printer data)

OPTIONAL EXTRAS

Windows based Software (Codesoft Premier package with Installation & details manual).
Encoder, rotary incremental (see pages 17 – 19)
Lower Roller Unit. (Custom Designed to fit the Open Date Frame)
Standard or custom designed mounting frame.
Ethernet & USB Communications (RS232 is standard)

PRINTER TECHNICAL INFORMATION

Maximum print area = 53.3mm X 500mm.
Printhead resolution in dots 12 dots/mm or 305 dots per inch.
3.5 Megabytes (approximately) memory for storing fonts, graphics and custom designed formats.
Print designs are stored along with all parameters, allowing quick access for printing.
Automatic updating of printer memory when editing formats.
Supply Voltage 110 or 220 / 240 V 50/60hz.
Real Time/Date printing with specified offsets if required.
Sequential Numbering and Barcode printing
All text, graphics, lines and boxes can be printed in all four orientations. (0, 90, 180, 270 degrees)

INSTALLATION PROCEDURES

Installing the 53CR Continuous Printer on a Standard Continuous Frame

1. Install the right hand printer into the Standard Continuous frame, utilising the “**location sleeves**” and then lock the “**clamp handle**” (see below)
2. Fit the retaining screws for the linear block adjustment. (See below)

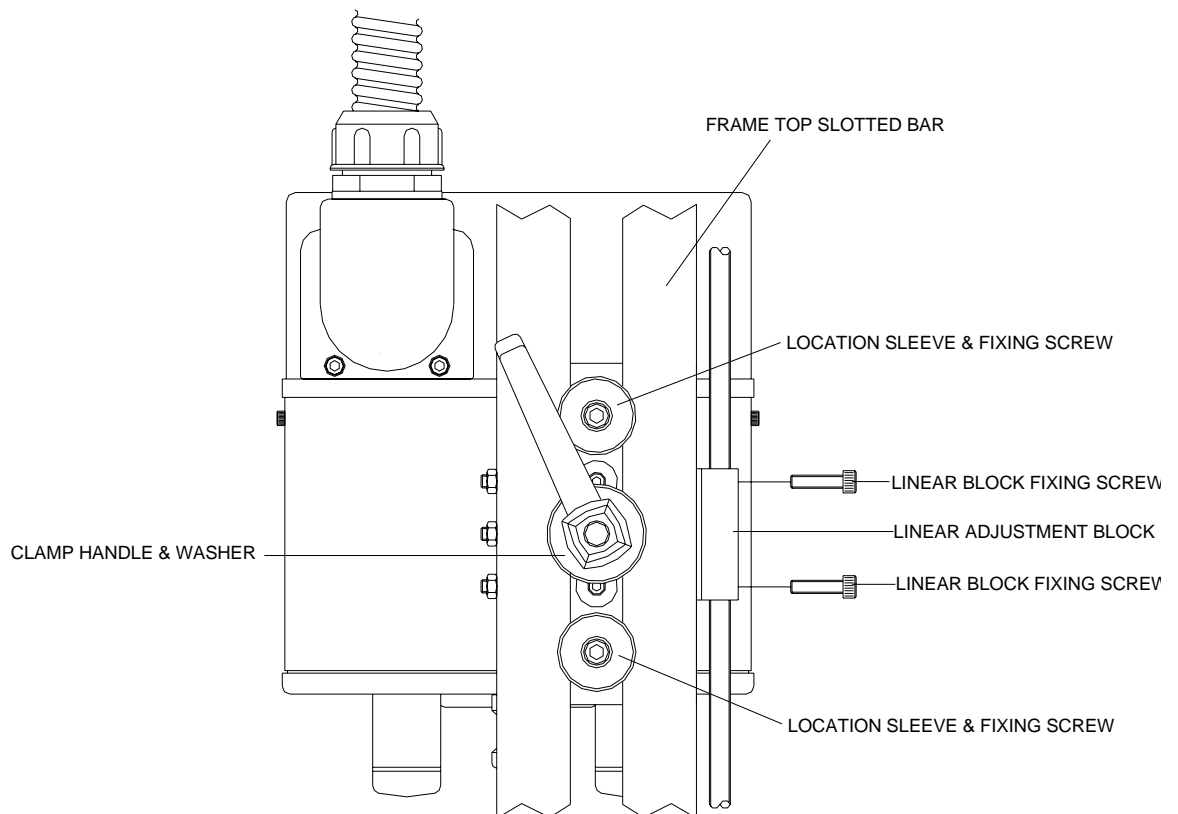

Checking the Printhead Angle

1. Check the “**printhead angle**” has been set correctly remove the magazine to visually check the mechanical angle setting. Within the mini-display unit, select the “**Service Menu**” number 4 **Print head data**, and check the printhead angle has been set correctly.

If the angle does not correspond, release the “**Printhead Locking Screws**” and adjust until the pointer is set correctly (See fig 2a Page 8) It may be necessary to switch off all electrics and remove the printer to a well-lit area to carry out this fine adjustment.

Enlarged View of Printhead and Pressure Roller Alignment

FIG 2a

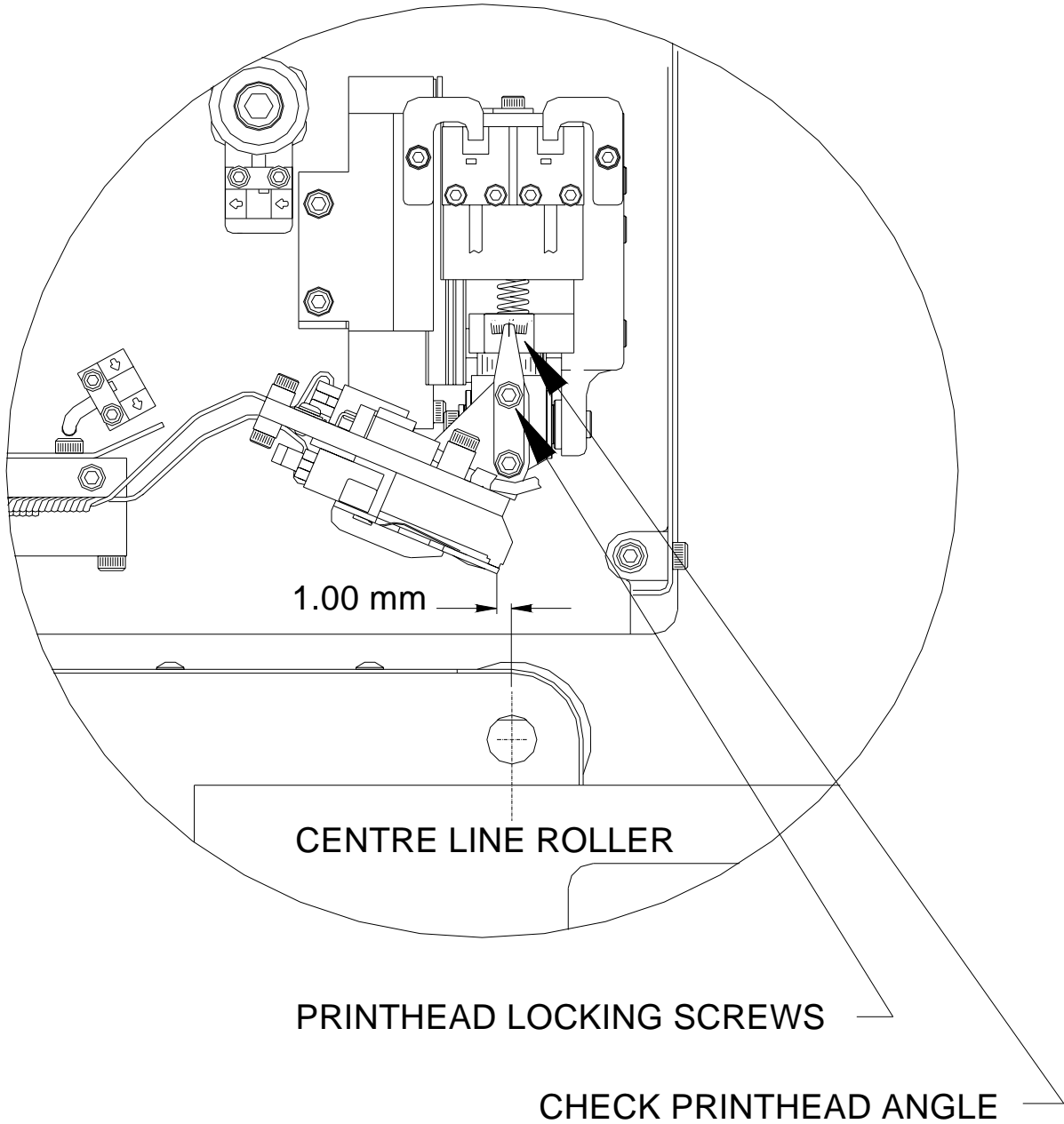

FIG 2B

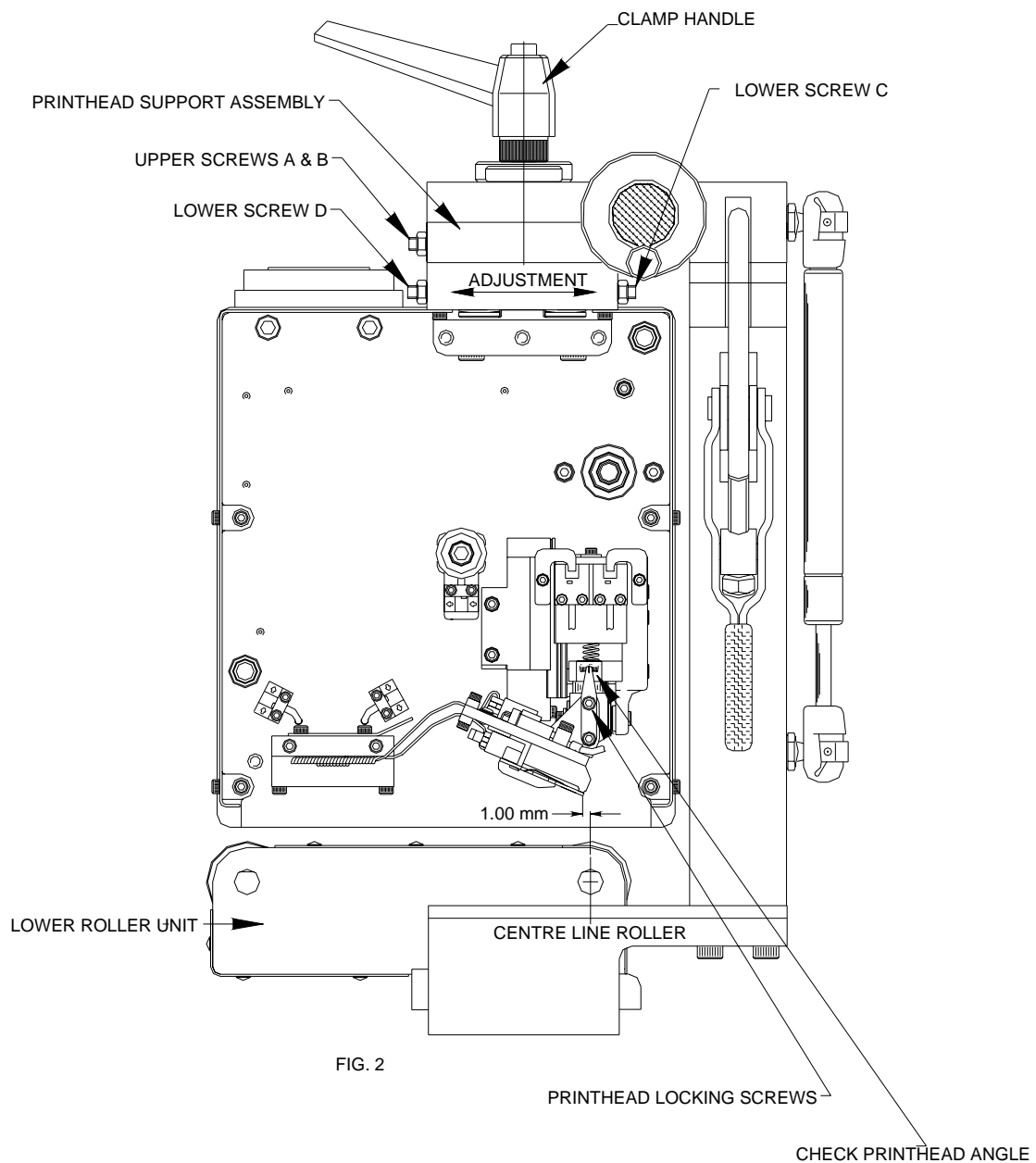

FIG. 2

Align the Printer to be adjusted correctly in the Standard frame, set the Printhead to be behind the print roller centre-line at "1.0 mm" dimension. (See above)

- A. Release the "Clamp Handle" by a quarter turn. (See above)
- B. Adjust the "Lower Screw D", undo by half a turn. (See above)
- C. Adjust the "Lower Screw C", do up by half a turn. (See above)
(Lower Screw C is the opposite side of the frame)
- D. Lock up Clamp Handle. (Once correct, lock up lock nuts)

Alignment of right hand Printer to the Lower Roller Unit

- A. Release the “**Clamp Handle**” by a quarter turn. (See below)
- B. Adjust the “**Upper Screw B**”, undo by half a turn. (See below)
- C. Adjust the “**Upper Screw A**”, do up by half a turn. (See below)
- D. Lock up Clamp Handle.
- E. Test a print an image, to show the printer is aligned to the Lower roller Unit.

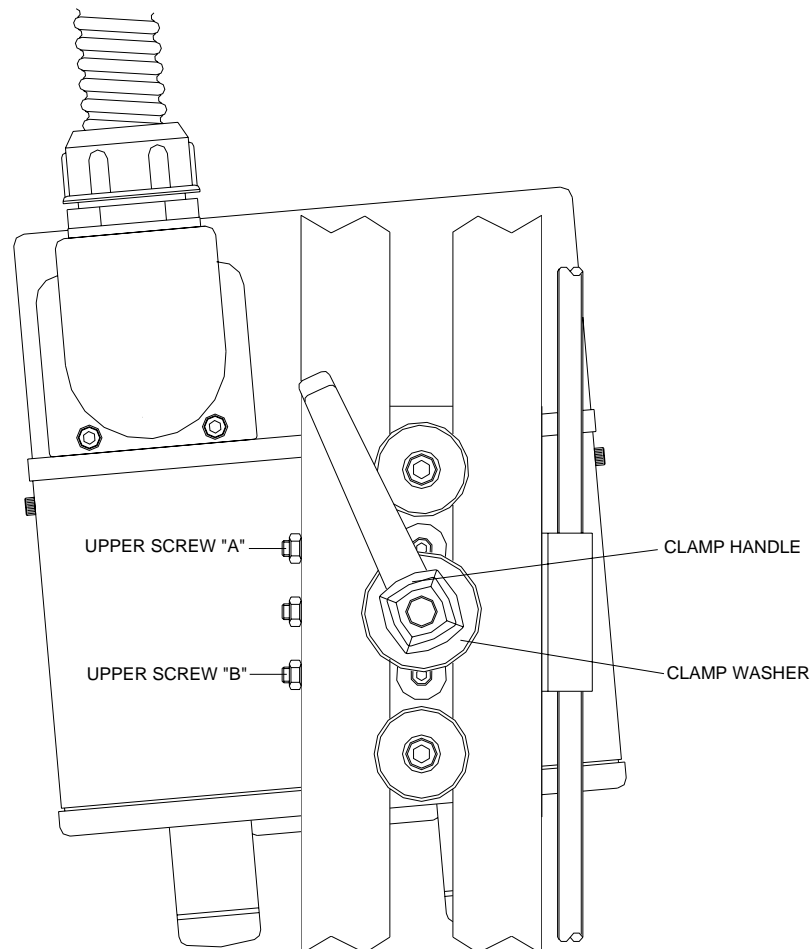

If the printer is aligned opposite to the above shown diagram, just reverse the adjustment procedure. By Adjusting the “Upper Screw A” before “Upper Screw B”.

You may have to repeat the procedure to ensure the printhead is aligned to the lower Roller unit correctly.

Installation Notes

1. Installing the **Thermocode 53CR** printer in a Standard mounting frame may not be required, but please check that all frame dimensional details needed are attained. It is very important that the alignment to the print roller is correct (see pages 8, 9 & 52
2. frame details etc.)
3. Connect the printer and power supply using the interconnection lead supplied. The lead has been specifically designed, so it cannot be fitted incorrectly. Please ensure that the plugs and sockets are inserted fully before tightening the fixing screws. Orientation of the mounting plate can be changed, by removing the two fixing screws. Then rotating the mounting plate.
4. Each installation must have an automatic print signal from the parent machine, this is normally a relay (voltage free) or 24 Volt pulsed output signal.

Five Volt Adjustment

If a Printer is to be fitted with a special length interconnection cable (3, 5 or 6 Metres), please ensure that the **5 Volt DC** supply at the Printer is adjusted to **5.1 Volts**, otherwise the Printer may not function correctly. This can be measured on Pin 5 and Pin 9, of the 9way "D" serial socket. The voltage is adjusted via the Potentiometer on the front right hand side of the power supply. See page 15

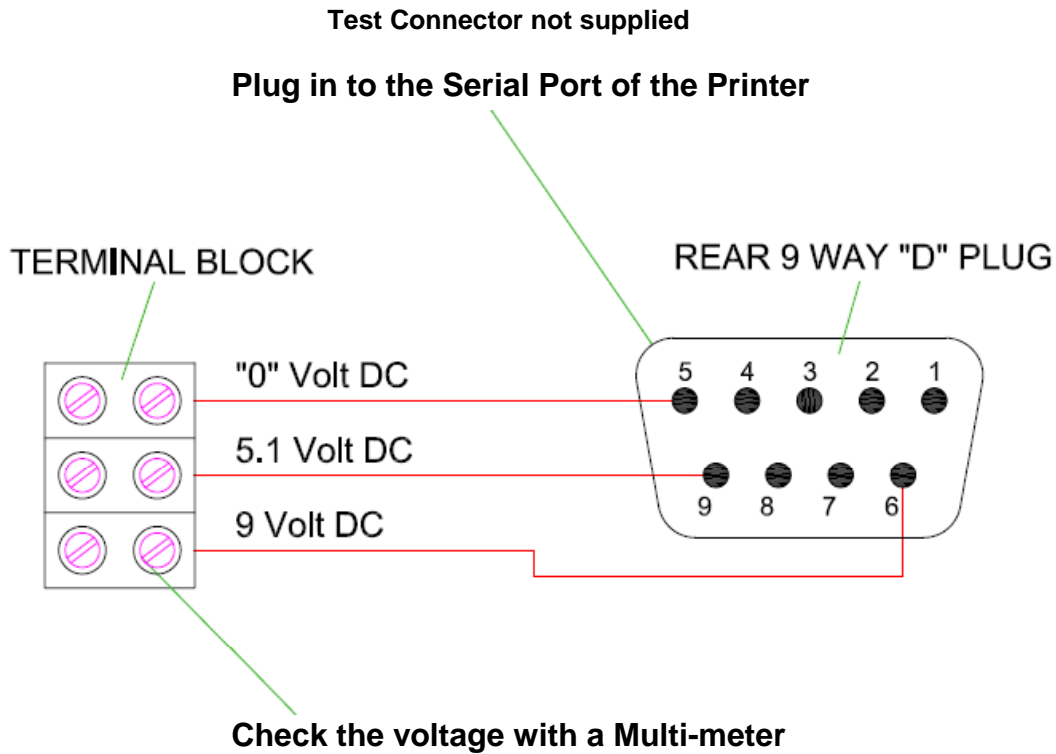

For more information on the Power Supply see: -

Page 12 & 13 for relay connections.

Page 13 & 14 for print signal connections.

Page 15 & 18 for power supply plan view (Page 15 with covers removed)

Page 18 & 19 for power supply Encoder Connections

The print signal can be delayed upon installation if required. Within the Supervisor menu on the mini-terminal display, there is a "Delay Menu" which allows the operator to change the print signal delay time. (Range 0 to 999 milliseconds)

Thermocode Series 2 Controlling Relays

Within the **Thermocode Series 2** Power supply are three relays, which can provide controlling signals to the parent machine. Each relay has three connections, **Normally Open**, **Normally Closed**, and **Common**. (Also see page 13)

The relays have a maximum rating of 240 Volt, 7 Amp. Through the Mini-Terminal software the installation engineer can configure each of the relays as required. (To set the options see page 28)

Relay 1 (4 options)

- <0> Stop Machine**
The relay operates after each print cycle giving a trigger/inhibit signal to the parent machine after printing or when the cassette is removed.
- <1> Sequence** (default software setting)
The relay operates after each print cycle giving a trigger/inhibit signal to the parent machine after printing.
- <2> Ready**
The relay operates when print images are being generated etc. (When the printer is off line)
- <3> Future Development**
- <4> 100ms pulse**
The relay is pulsed for a 100 milliseconds

Relay 2 (5 options)

- <0> Start Machine**
The relay operates after each print cycle giving a trigger/inhibit signal to the parent machine after printing or when the cassette is removed.
- <1> Low Foil** (default software setting)
The relay operates when the amount of Thermal Ribbon left in metres reaches a pre-programmed amount, and is visually indicated to the operator "Low Foil" on the status line of the Mini-Terminal Display.
- <2> Ready**
The relay operates when print images are being generated etc. (When the printer is off line)
- <3> 100ms pulse**
The relay is pulsed for a 100 milliseconds
- <4> 100ms pulse**
The relay is pulsed for a 100 milliseconds

Relay 3 (4 options)

- <0> Fault Only**
The relay operates when the printer's internal sensors detect a fault or error condition. Typical examples of this are when the Cassette is removed or if the Thermal Ribbon is broken.
- <1> Fault & Ready** (default software setting)
The relay operates as option 1, but will also operate when print images are being generated etc. The relay should be connected to inhibit the parent machine should any printer fault occur.
- <2> Future Development**
- <3> 100ms pulse**
The relay is pulsed for a 100 milliseconds
- <4> 100ms pulse**
The relay is pulsed for a 100 milliseconds

Power Supply (I/O Board connections)

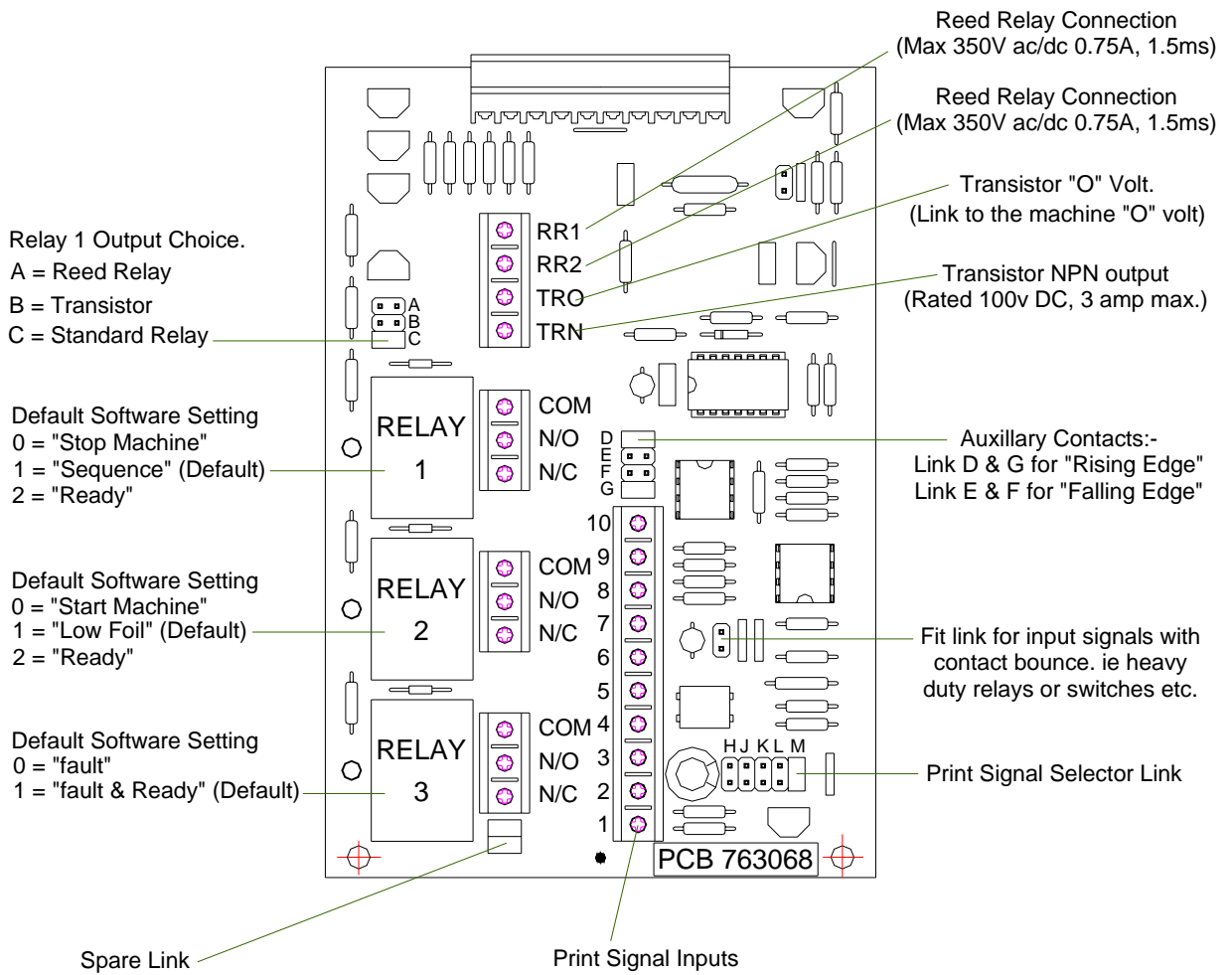

Voltage Free Connections:- Connect wires to terminals 1 & 2.
 (fit Print Signal Selector to "M" only as shown)

Input (9 - 50 volt DC):- Connect wires to terminals 3 & 4, polarity unimportant.
 (fit Print Signal Selectors to positions "J" & "L" only)

Input (6 - 35 volt AC):- Connect wires to terminals 3 & 4, polarity unimportant.
 (fit Print Signal Selectors to positions "J" & "L" only)

PNP / NPN Sensor or Volt Free Connections

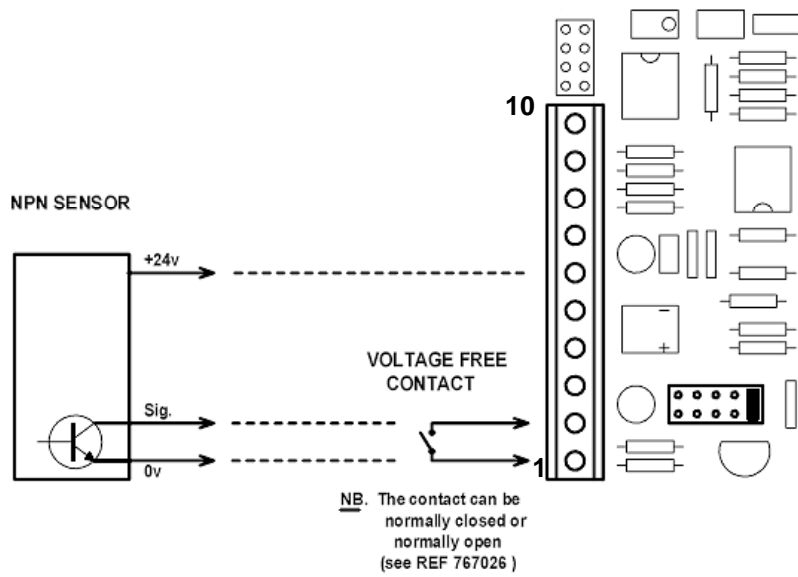
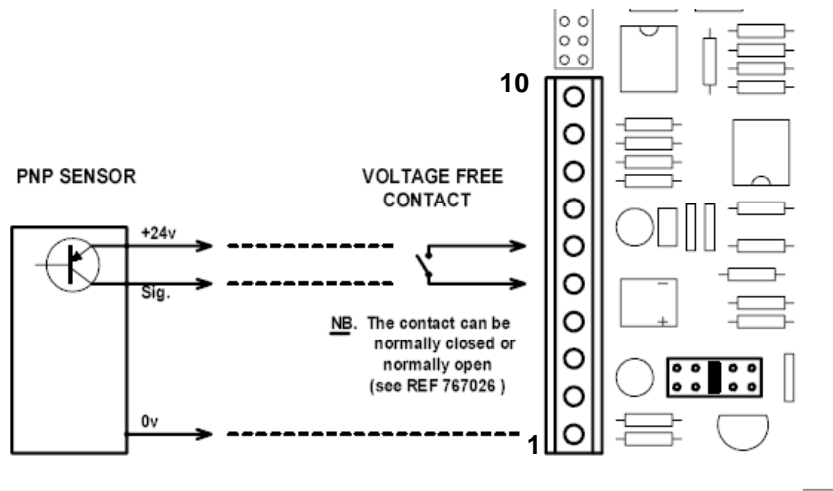

Note: - The above drawings, are for 24V DC sensor deriving their power from the Thermal power supply. When the sensor has its own power supply, leave off the +24V connection

Power Supply

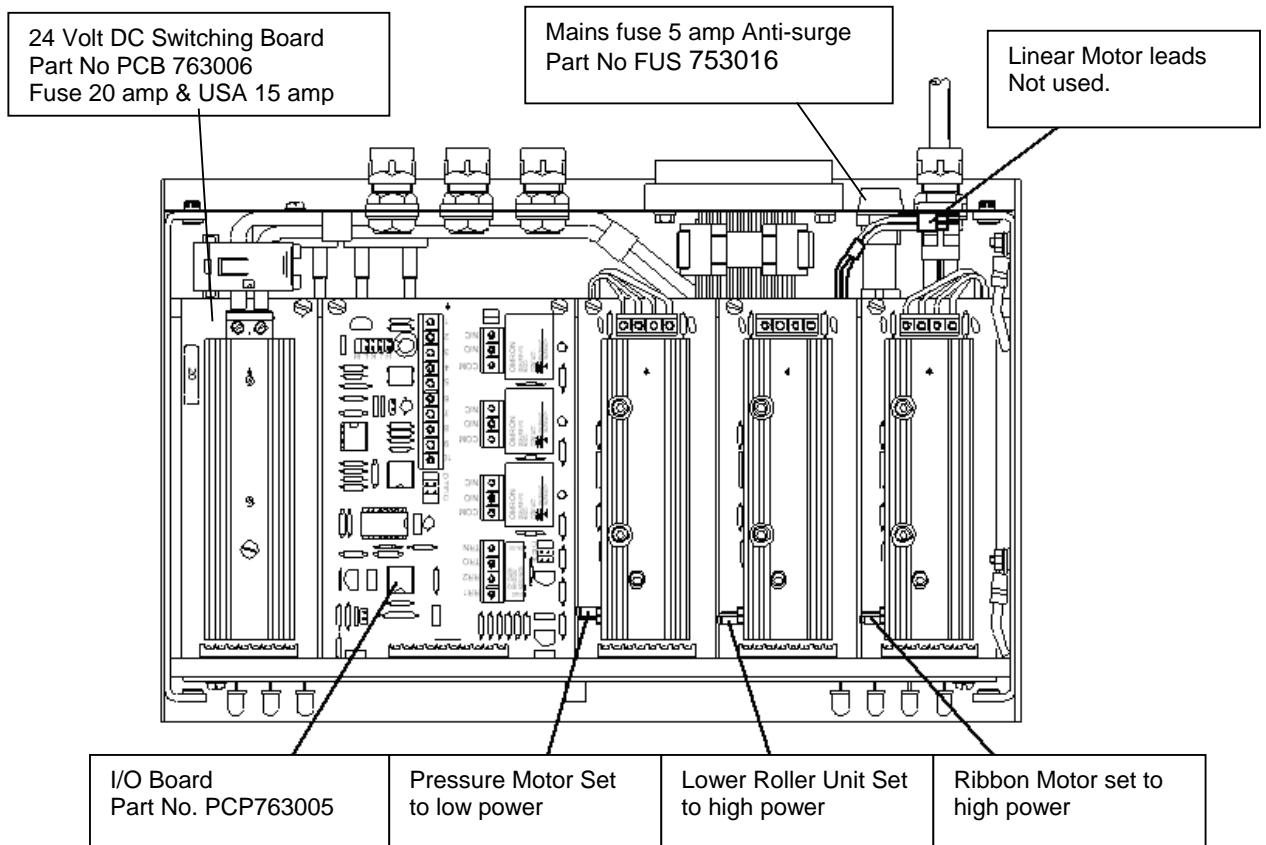
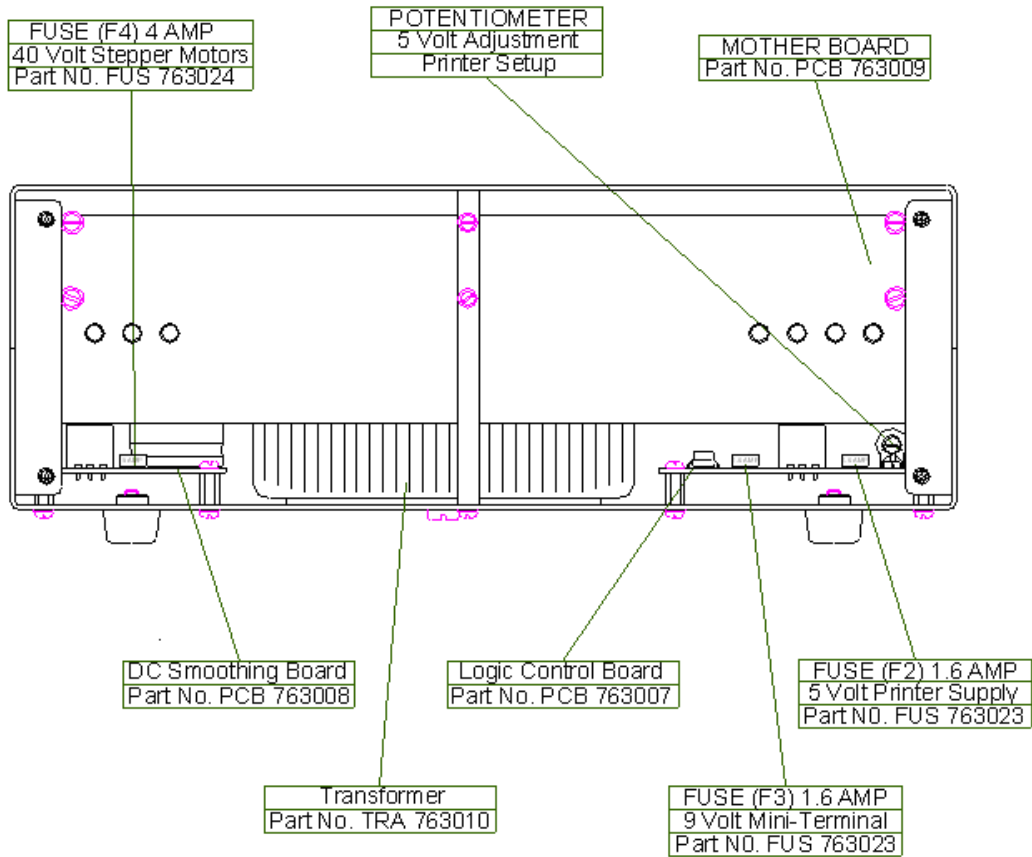

Note: - All Stepper drive boards are the same. **Part No. PCB 763004**

THERMOCODE SERIES 2 (Power Supply LED details)

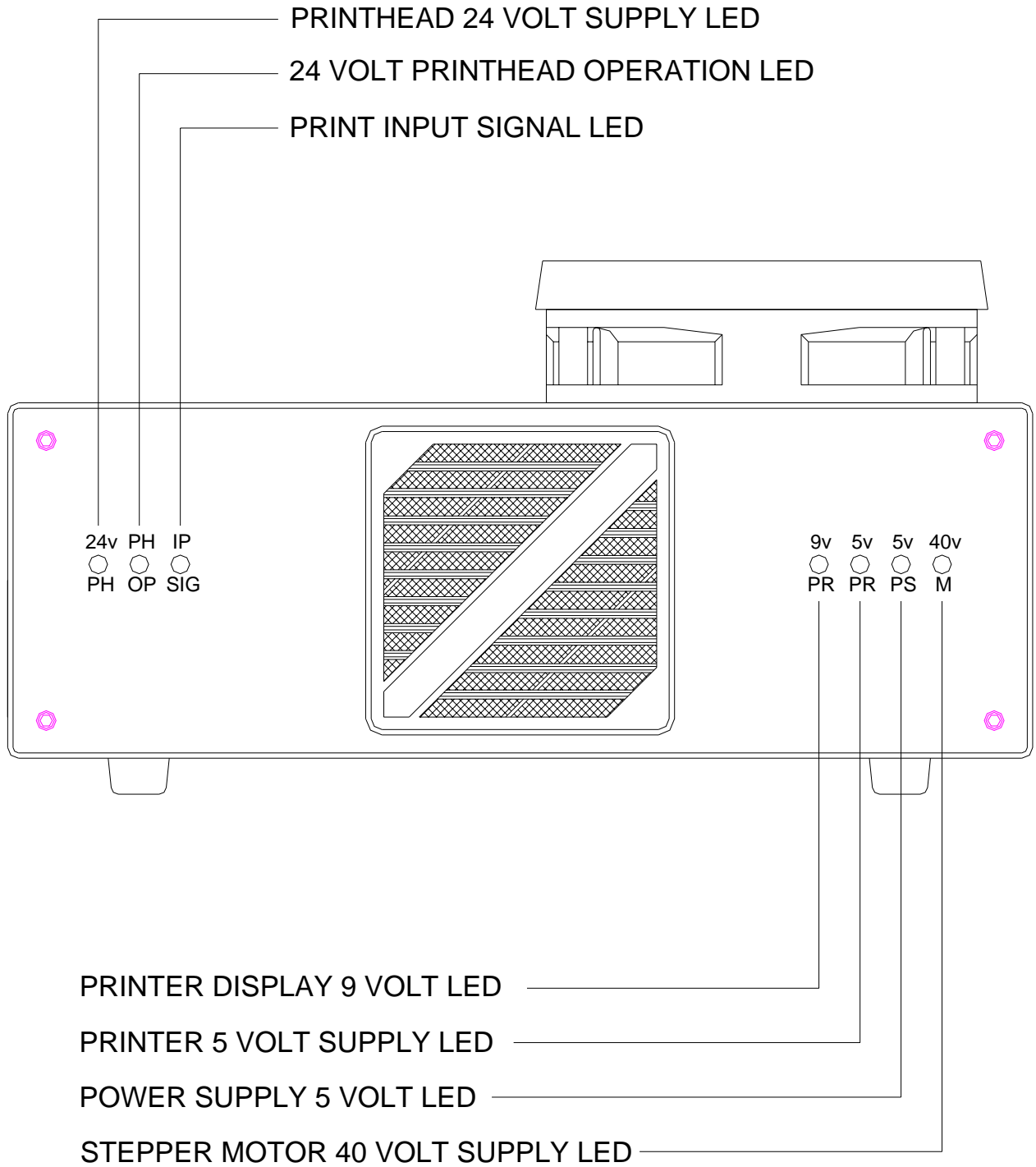

Encoder Description

Incremental encoders are commonly used as feedback devices for motor controllers. They also serve as operator interfaces and are sometimes called rotary pulse generators.

An incremental encoder is made up of 2 major parts: the internal disk and the sensor. The disk of an incremental encoder is patterned with a single track of repeating identical lines near the outside edge of the disk. The number of line pairs on the disk determines the encoder resolution.

Our standard encoder wheel has a circumference of 200mm and runs on the surface of the substrate. Thermocode Series 2 requires 2400 pulses per revolution.

Since the resolution of the Printhead is 12 dots per mm, we also require 12 pulses per mm down the web. Therefore one revolution of the encoding wheel is 200mm X 12, equals 2400 pulses.

Principles of an Incremental Encoder

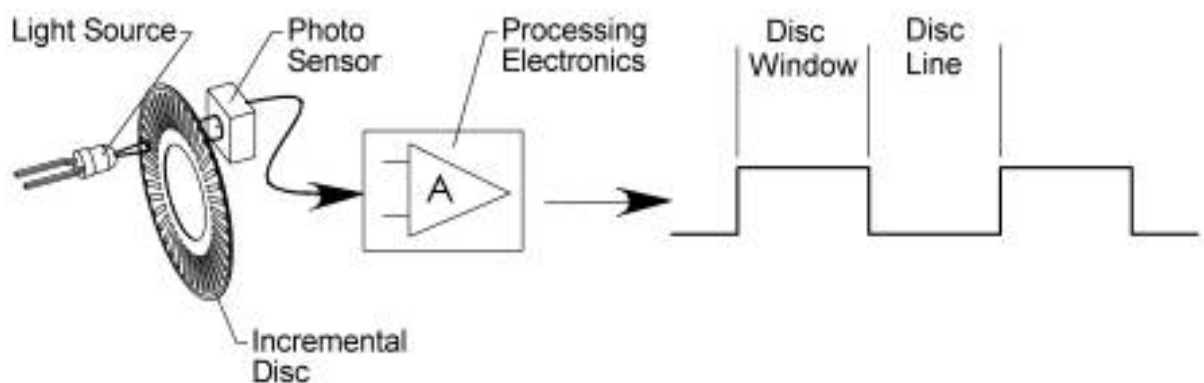

The Open Date Equipment standard encoder assembly is fitted with a measuring wheel on the output shaft, you will have to provide specific sprung loaded designed brackets to mount the unit on the parent machine. (Open Date Equipment Ltd can supply standard mounting brackets. Contact your local supplier)

You must ensure that no slipping happens between the substrate and the measuring wheel, otherwise printing quality, print registration or printer errors could occur.

If you need to fit an encoder inside a parent machine, not just running against the substrate I suggest you contact Open Date Equipment Ltd for technical assistance.

Power Supply Shaft Encoder & Lower Roller Unit Connections

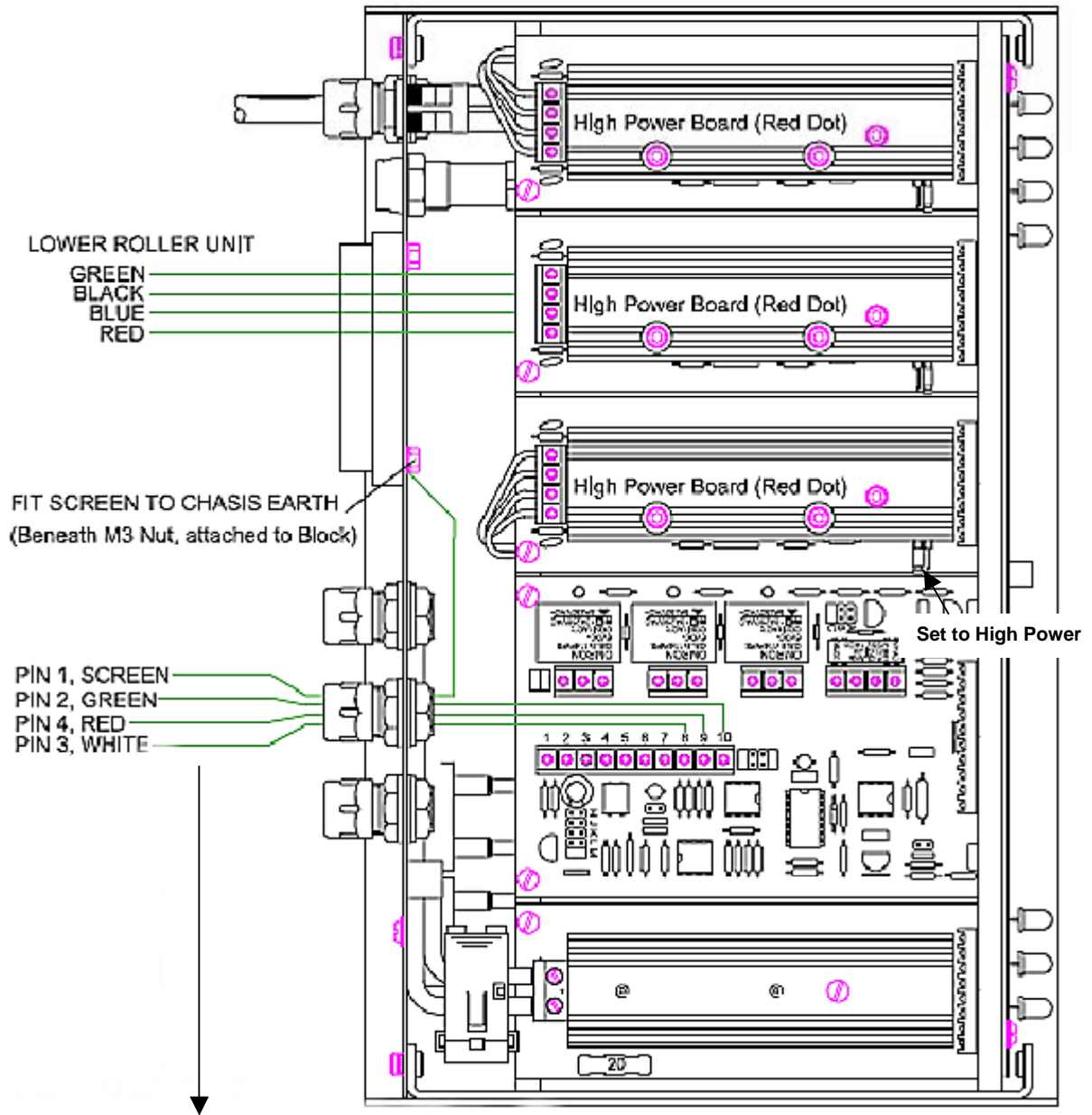

Cable Assembly Part No. ASY 765188
 Fitted with 8 Way Female Socket
 Pin 1= Black (Screen), Pin 2 = Green, Pin 3 = White, Pin 4 =Red



Encoder Type and Connections

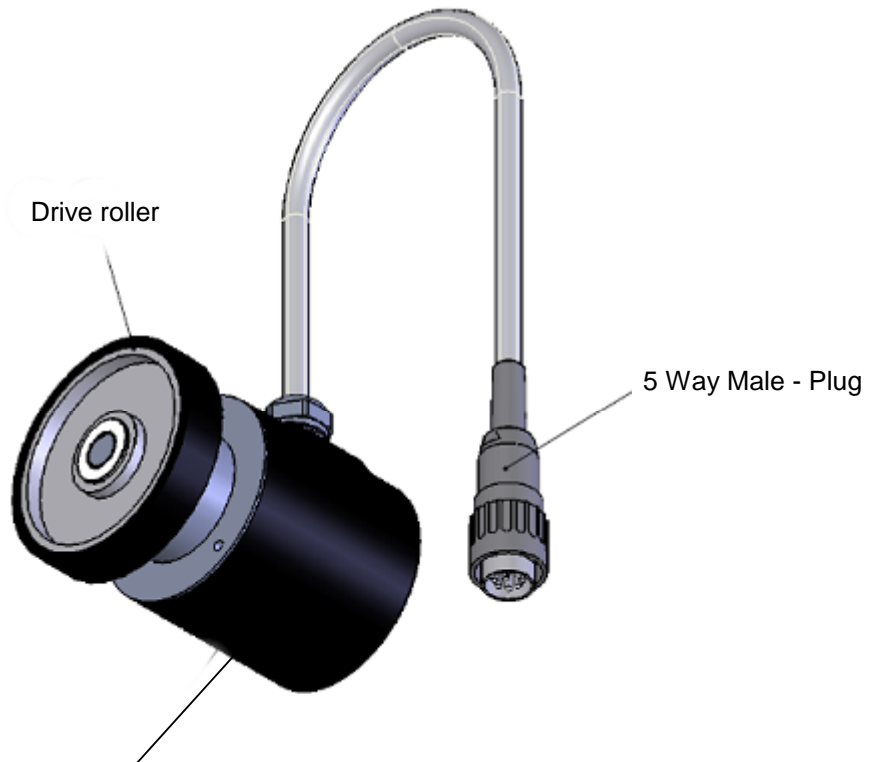

Encoder Make	Model / Type	Part Number & Plug	Encoder, Plug & Driver Roller
Principle Engineering	758-58mm	N/A	ENC765304
Kubler (Black)	5820.1288.2400.0020	No longer supplied	Replaced with above
Kubler (Orange)	8.5802.128B.2400.0020	No longer supplied	Replaced with above
Scancon	2RK2400-606904	No longer supplied	Replaced with above

Principle Engineering		Kubler (Black & Orange)		Scancon	
Wire Colour	Plug Pin No	Wire Colour	Plug Pin No	Wire Colour	Plug Pin No
Screen/Shield	1 & Case	Screen/Shield	1 & Case	Screen/Shield	1 & Case
Brown	2	Green	2	Pink	2
Black	3	White	3	Blue, Grey, Brown, Yellow	3
White	4	Brown	4	Red	4

Note

- Plug / Socket Pin 1 Connects to the power supply case (Screen)
- Plug / Socket Pin 2 Connects to the power supply terminal 10 Signal
- Plug / Socket Pin 3 Connects to the power supply terminal 8 0 Volts
- Plug / Socket Pin 4 Connects to the power supply terminal 9 5 Volts DC

SYSTEM START-UP SEQUENCE

Ensure if a standard mounting frame is used, it is fully closed before switching on the printer.

After switching on the following start up sequence screens will be displayed, this screen displays the communication baud rate that has been set.

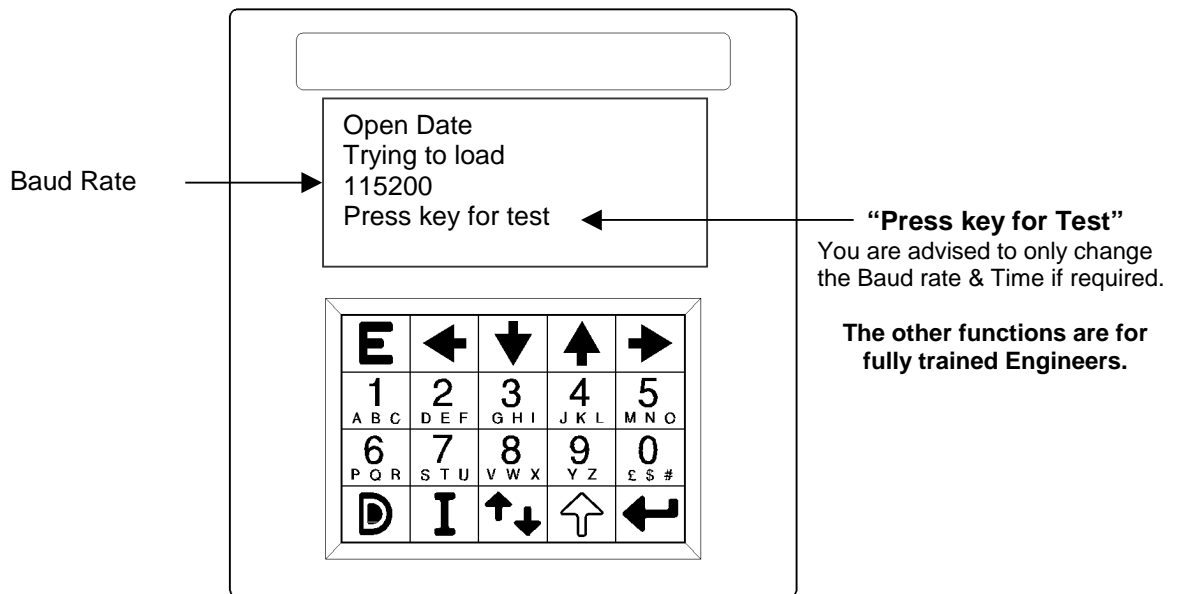

The following screen shows: -

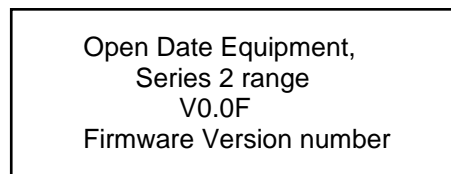

After a few seconds, the machine will check the printer through a standard sequence of operations to determine the maximum print length and then automatically select the printer size.

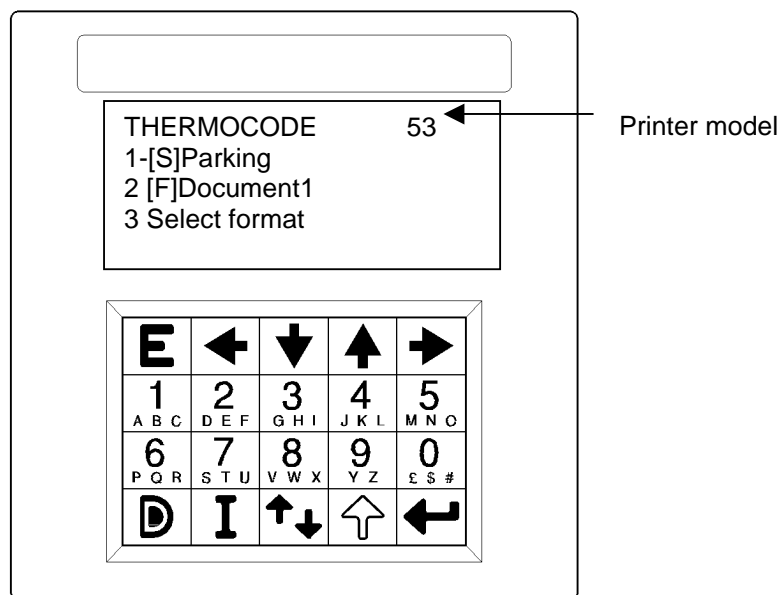

After determining the model of machine, automatically the height of the lower roller unit is detected. This measurement is used by the software and automatically adjusts the printer for the correct height above the lower roller unit. The screen shown on page 21 is after the start up sequence has finished, showing the actual model of the machine and the format that is ready to print.

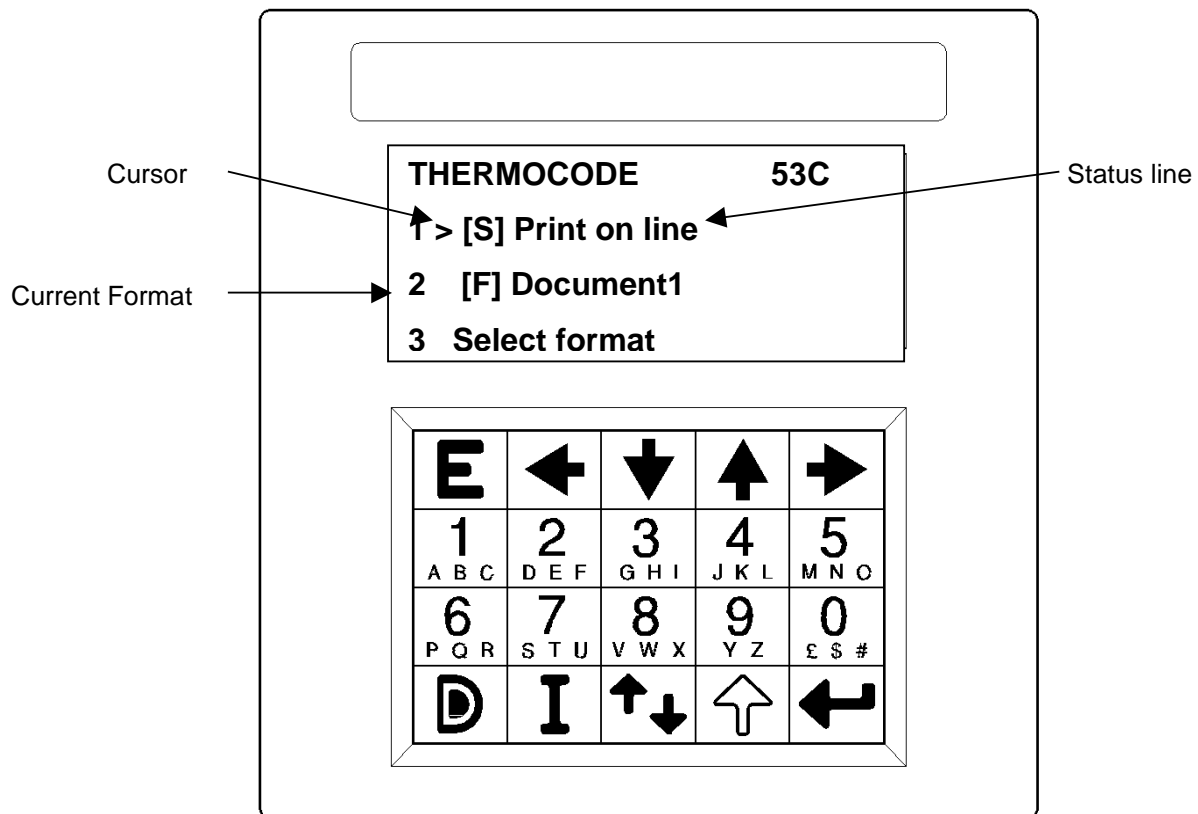

[F] Status Line

This line on the display shows the current status of the printer. If errors have occurred the display shows "error" and by either pressing the enter key when the cursor is next to the error or by just pressing "1" on the keypad all errors will be listed.

[F]Document1

This line on the display shows the current format image that is ready to print, pressing number 2 on the keypad will allow the user to edit all functions relevant to the design.

Note!

Accessing of all menu functions can be done by either of two ways: -

1. Move the cursor next to the function you wish to use and press "Enter".
2. Simply press the required number next to the function you require.

See next page for a full description of the keys on the mini-terminal display unit.

MINI TERMINAL (Key mapping)

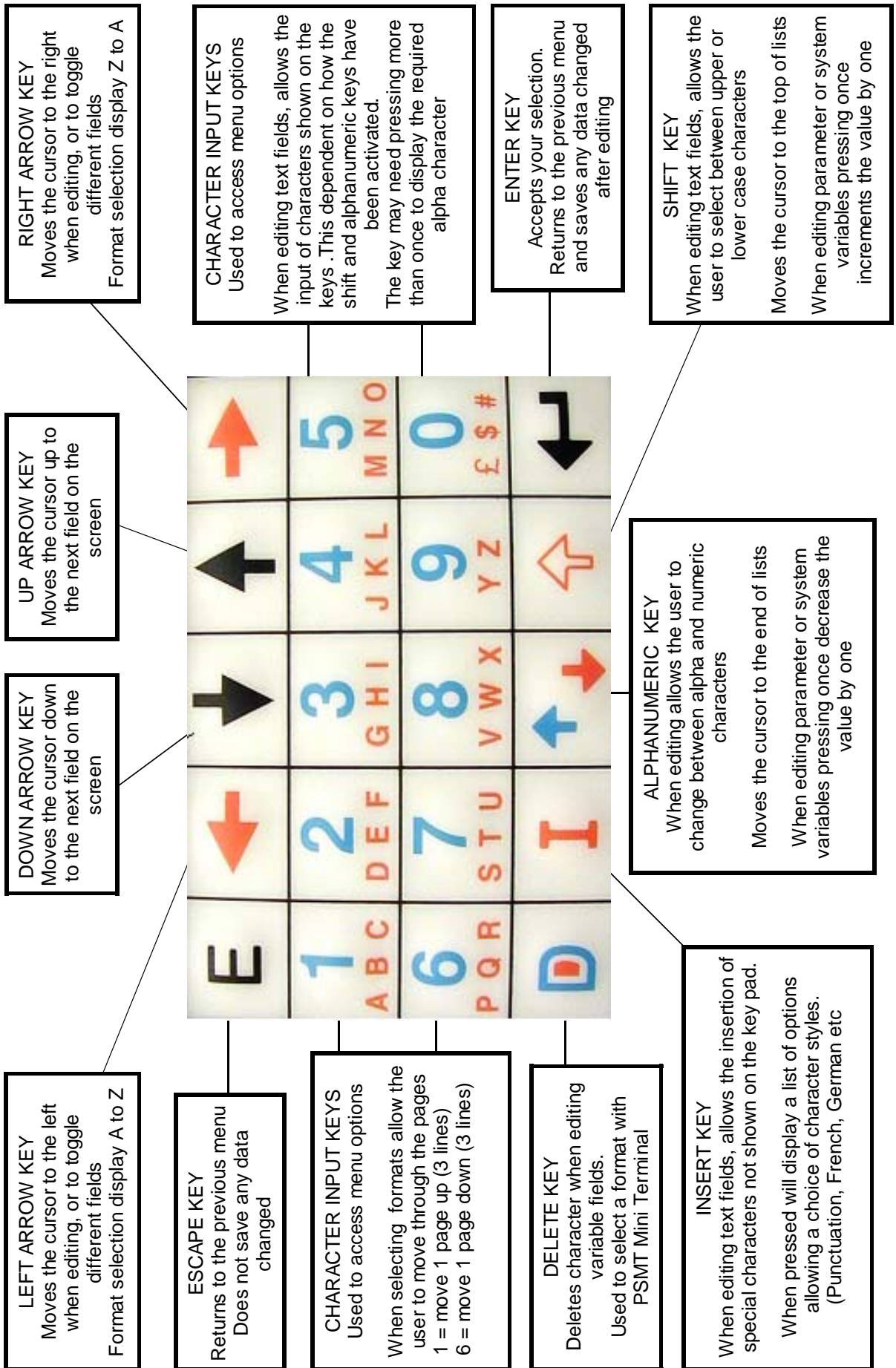

STATUS DISPLAY SOFTWARE FLOWCHARTS (Level 1: OPERATOR)

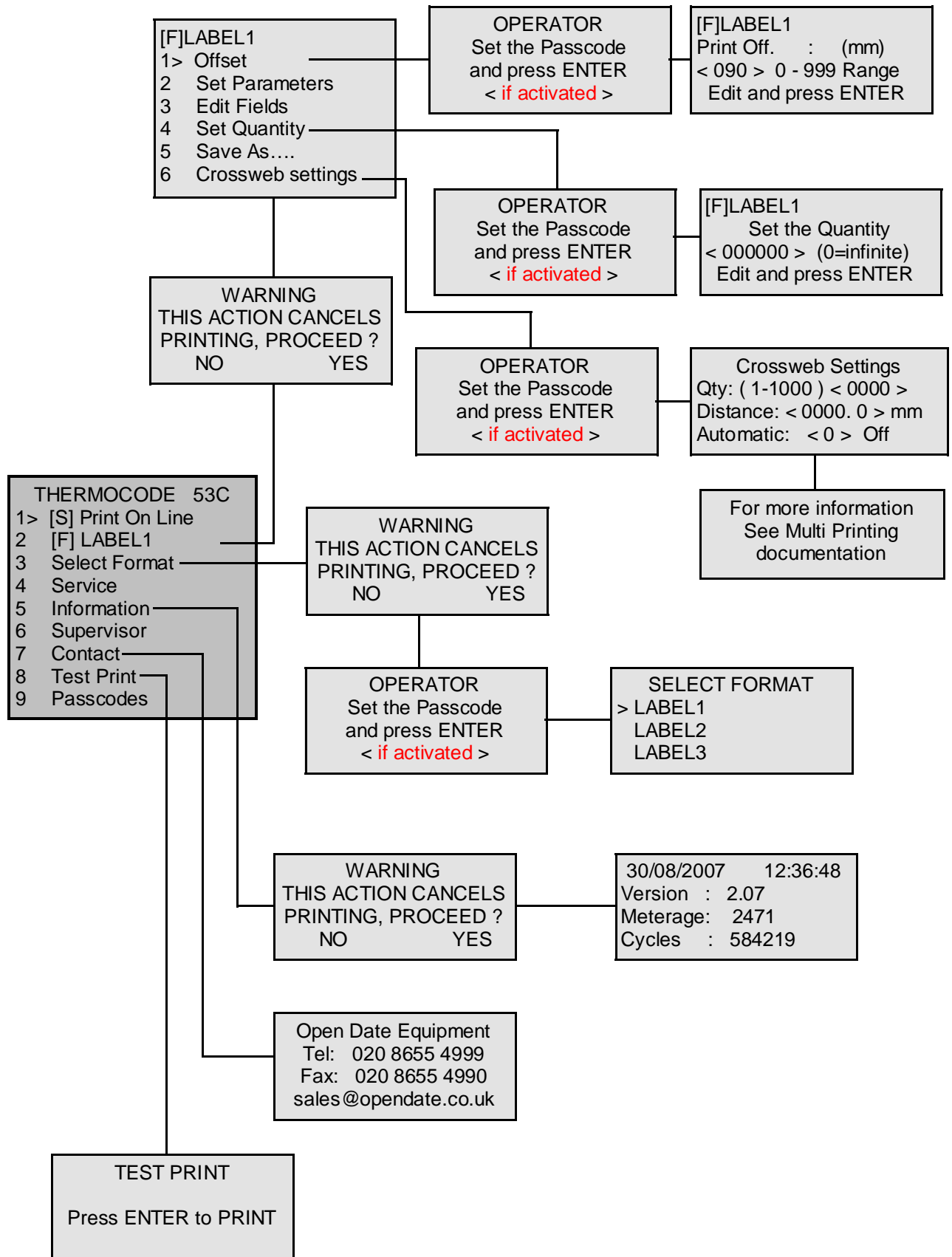

STATUS DISPLAY SOFTWARE FLOWCHARTS (Level 2: CHARGEHAND)

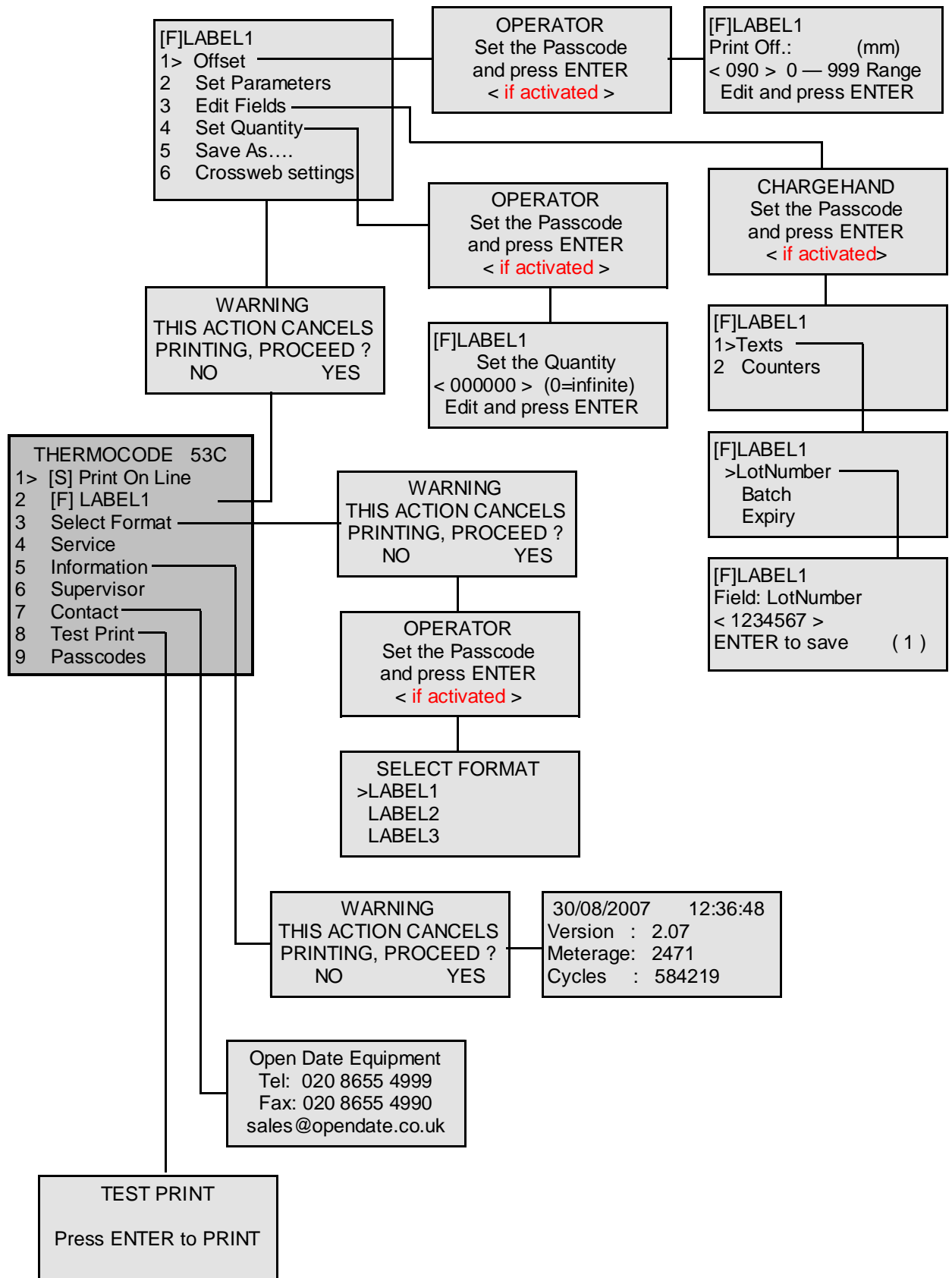

STATUS DISPLAY SOFTWARE FLOWCHARTS (Level 3: ENGINEER)

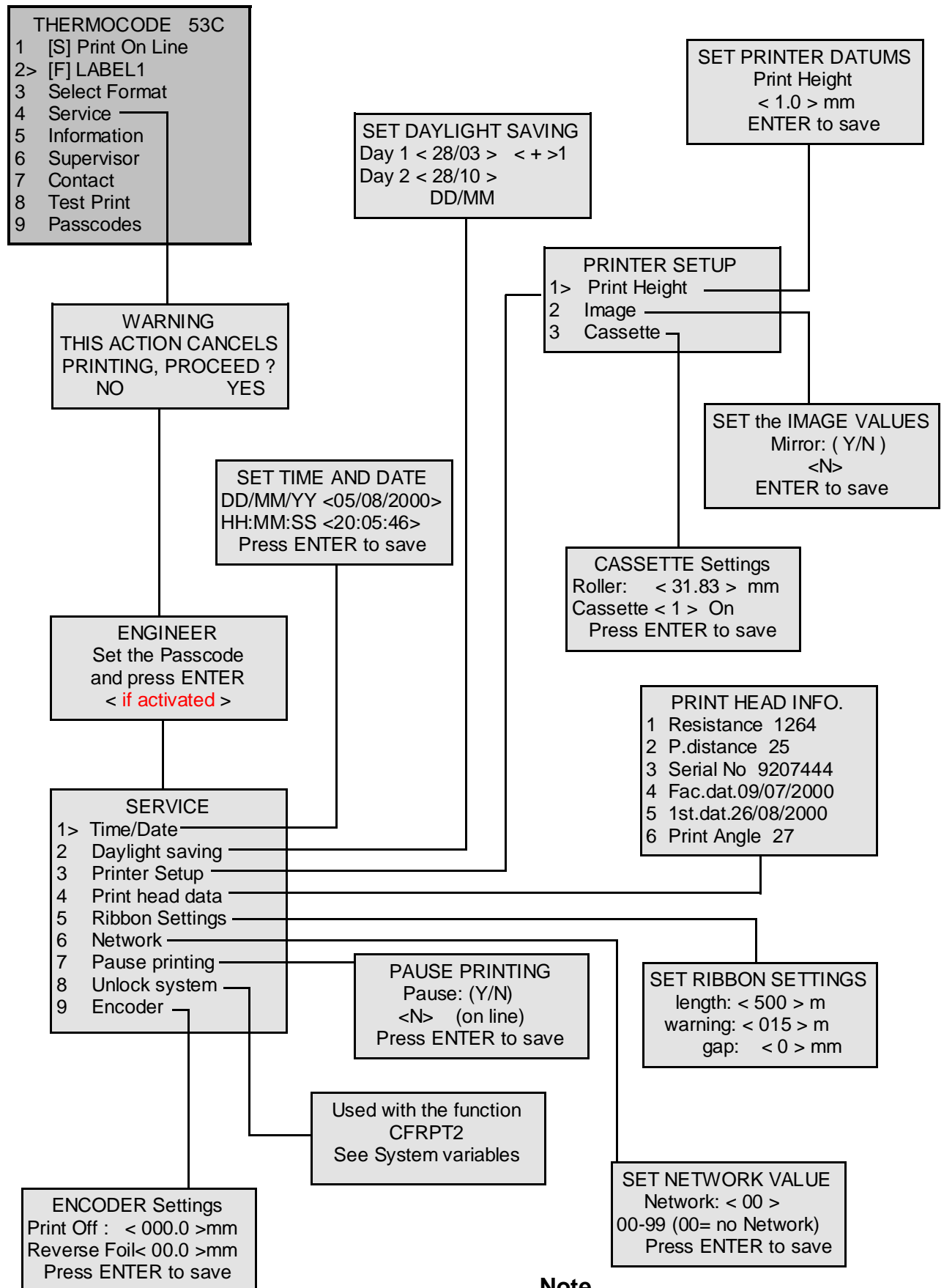

Note
6 > Network
 Refers to Open Date's Network system
 and is no longer available

STATUS DISPLAY SOFTWARE FLOWCHARTS (Level 3: ENGINEER)

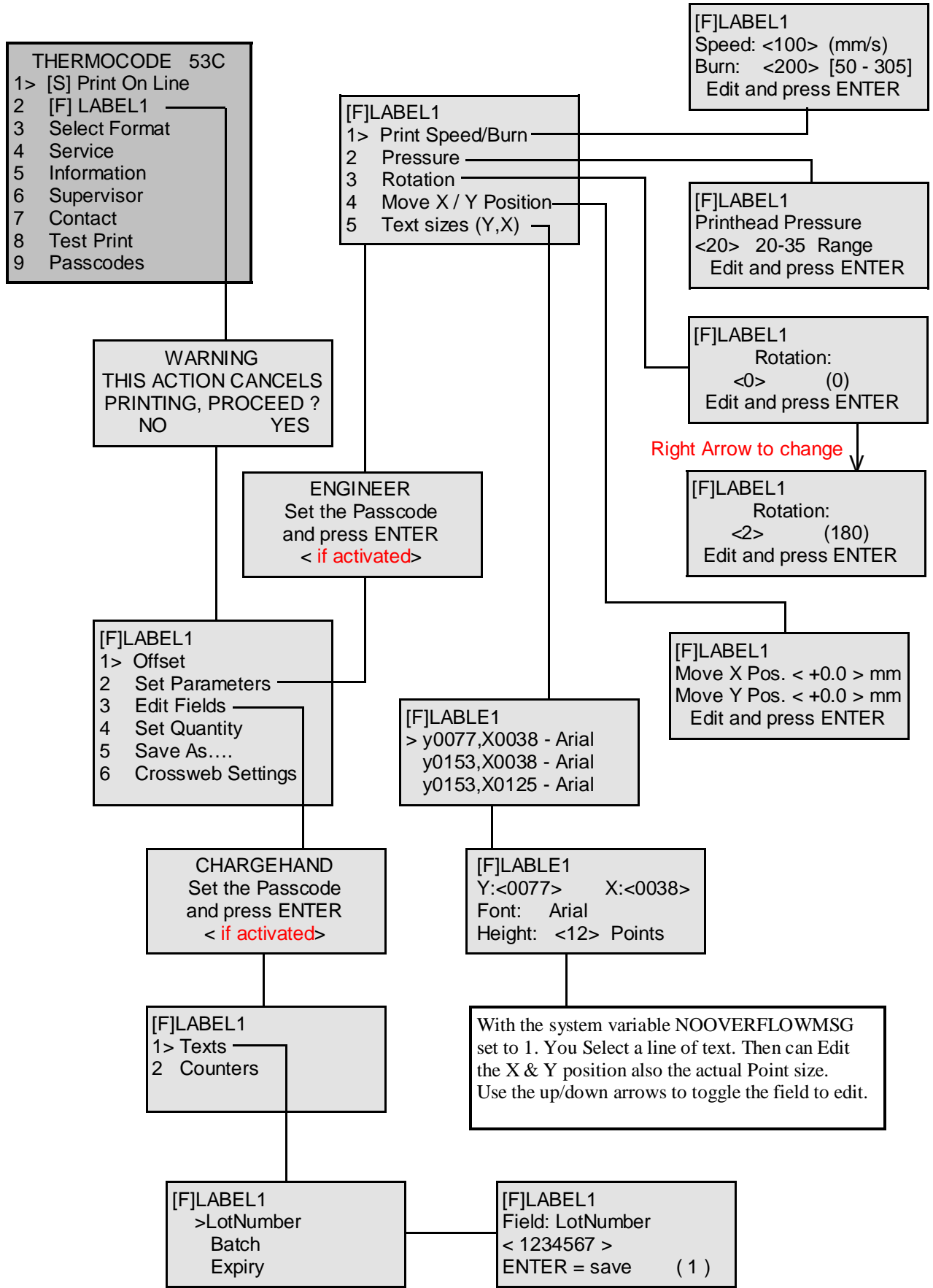

STATUS DISPLAY SOFTWARE FLOWCHARTS (Level 4: MANAGER)

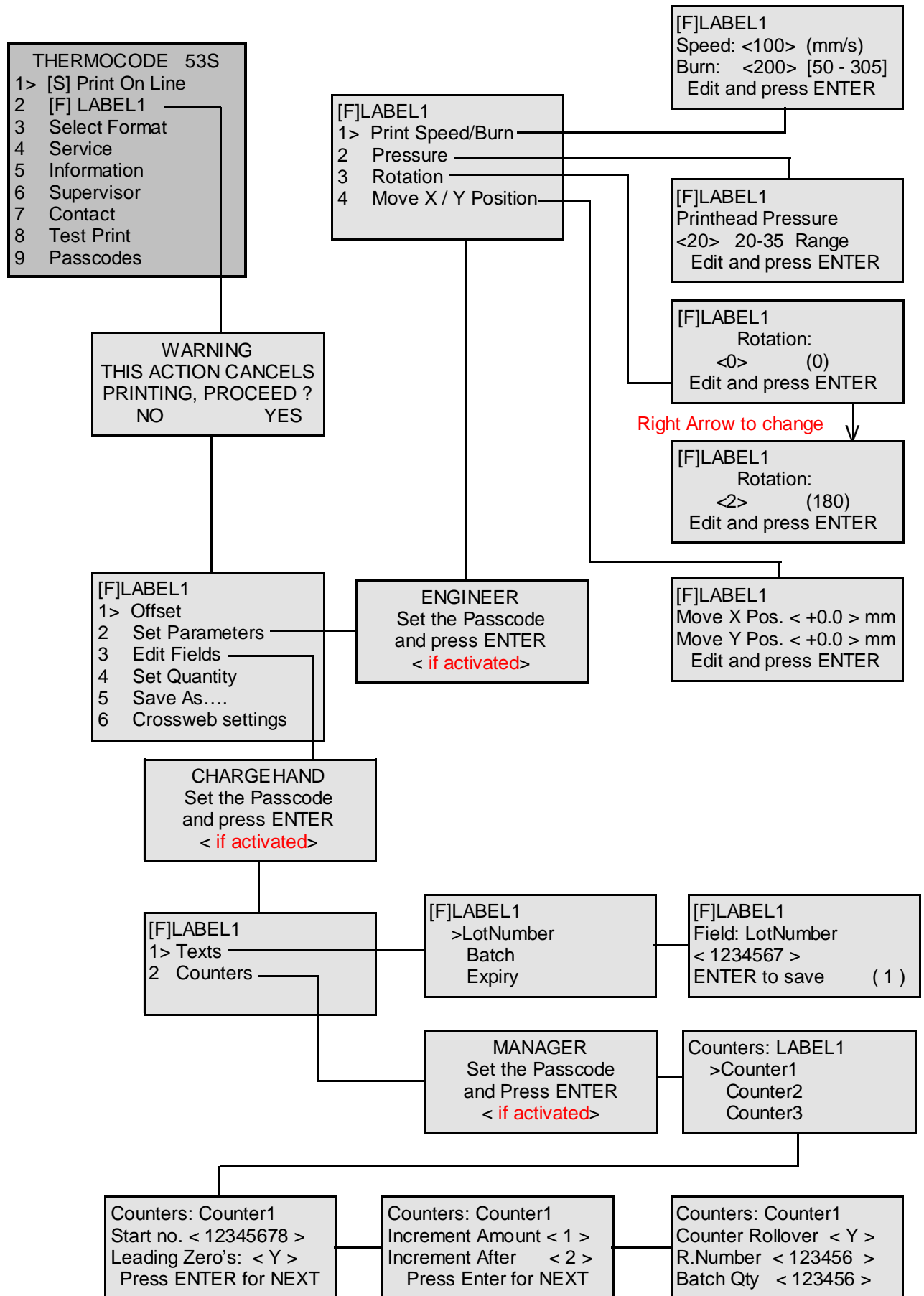

STATUS DISPLAY SOFTWARE FLOWCHARTS (Level 5: SUPERVISOR)

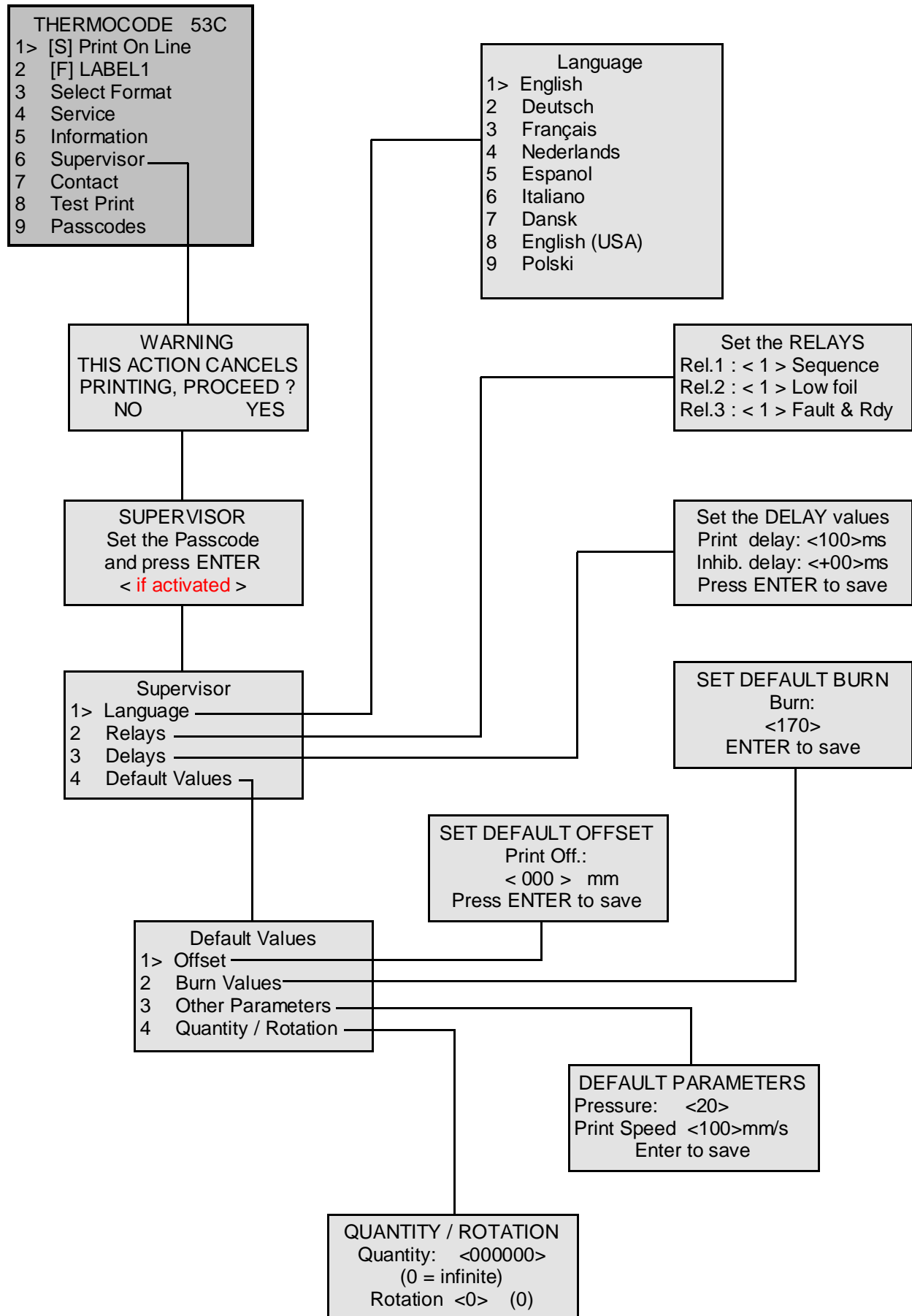

STATUS DISPLAY SOFTWARE FLOWCHARTS (Level 7: PROGRAMMING)

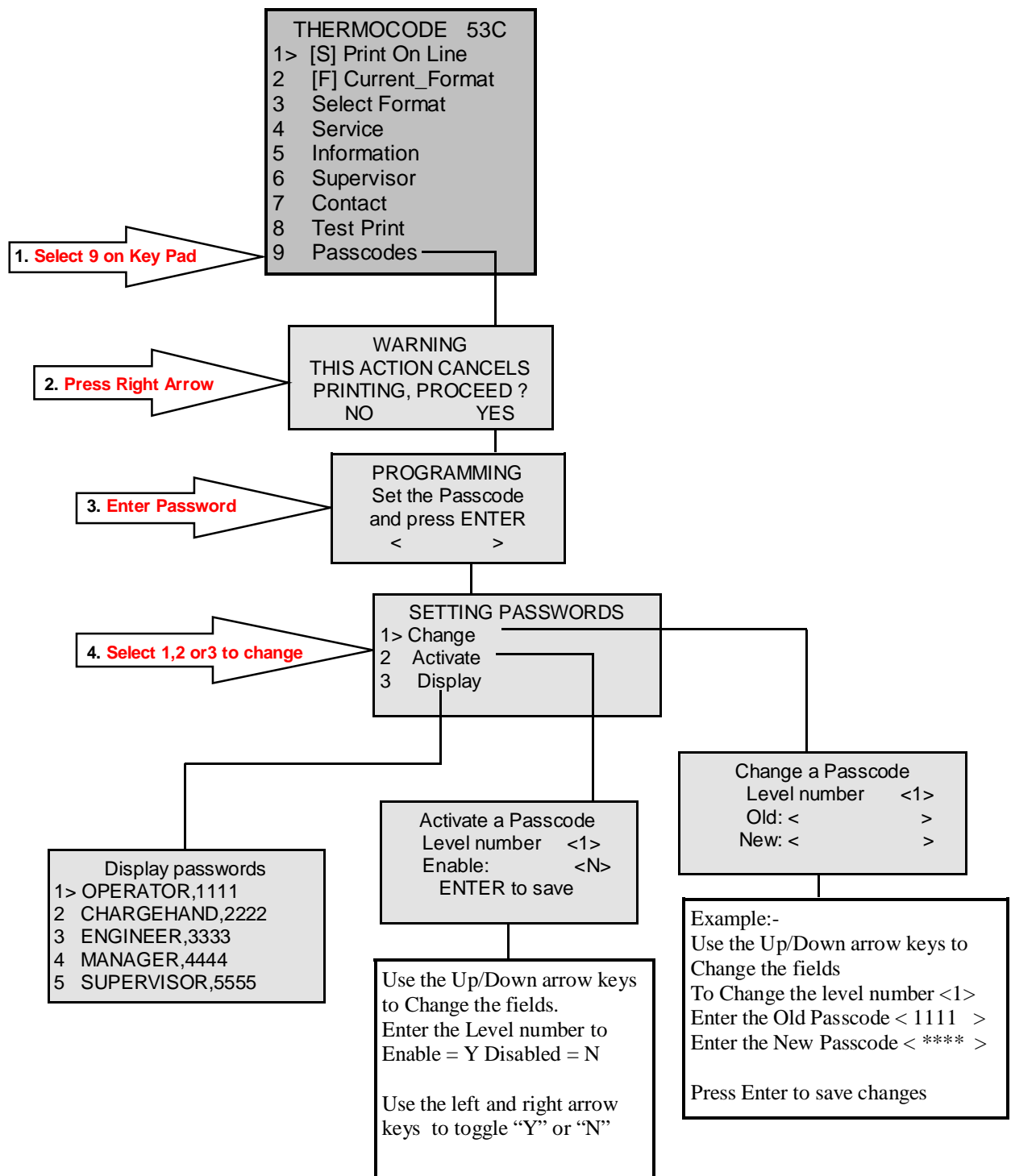

Editing Text Fields

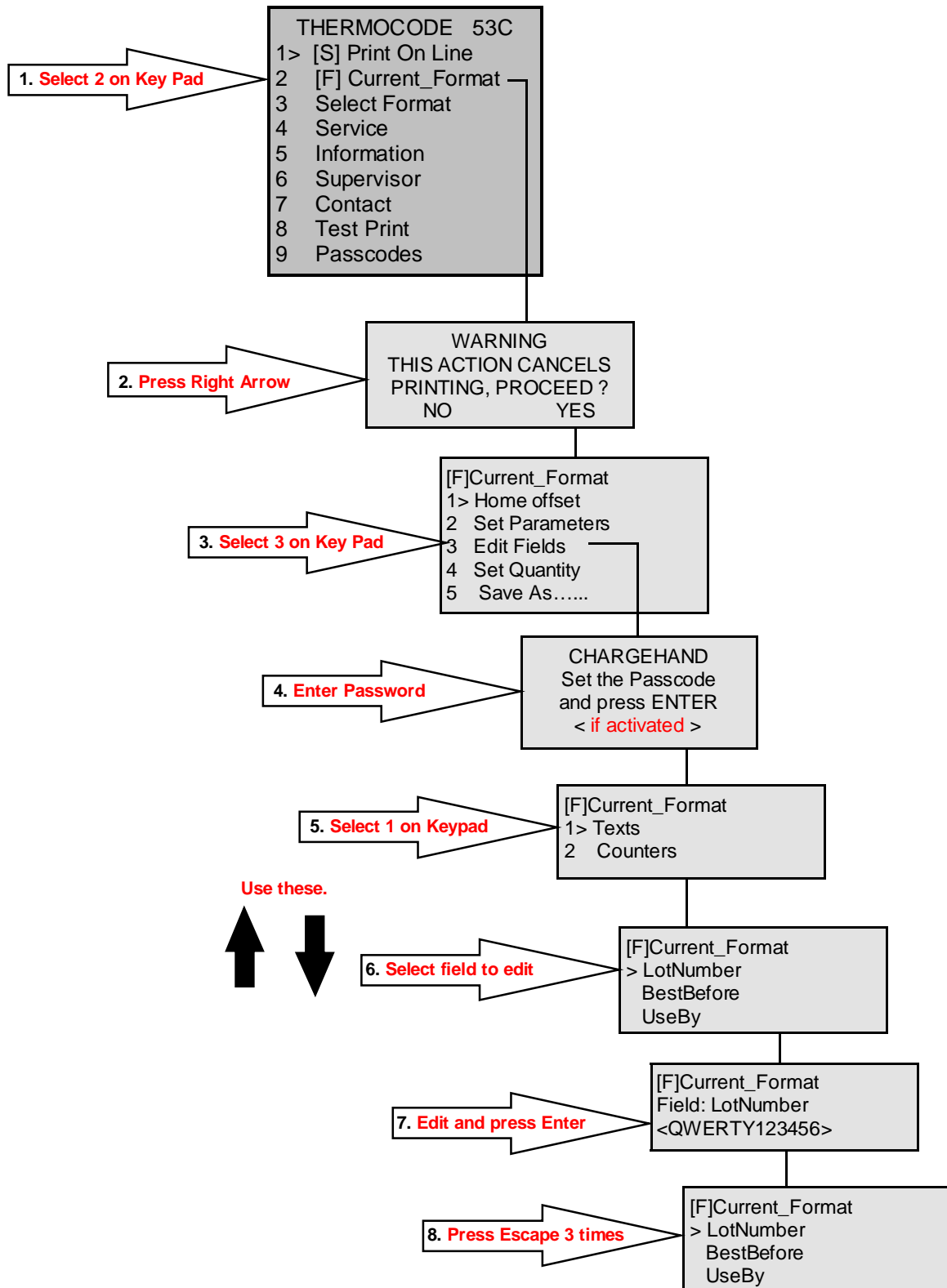

Selecting a New Format

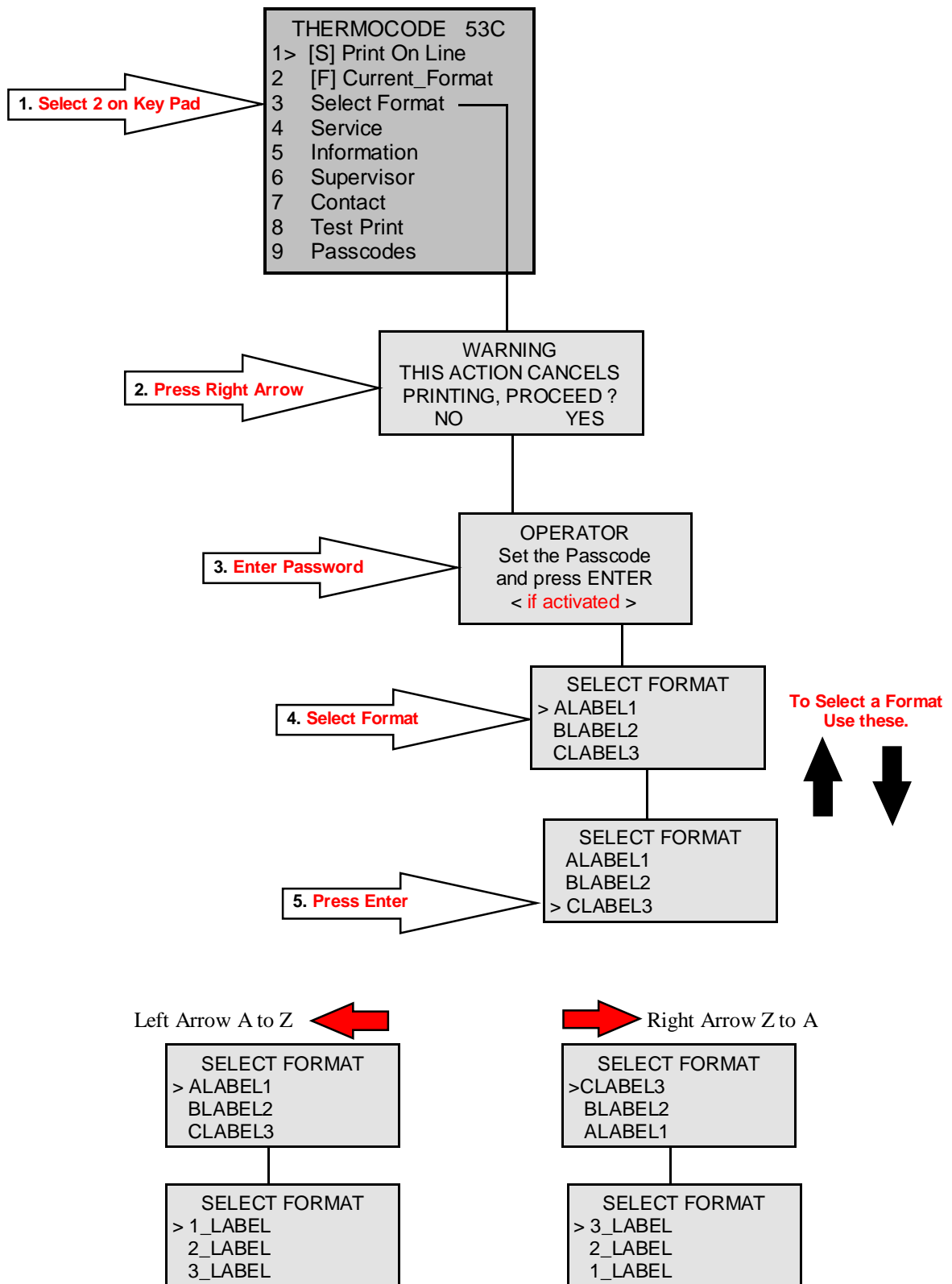

Making Test Prints

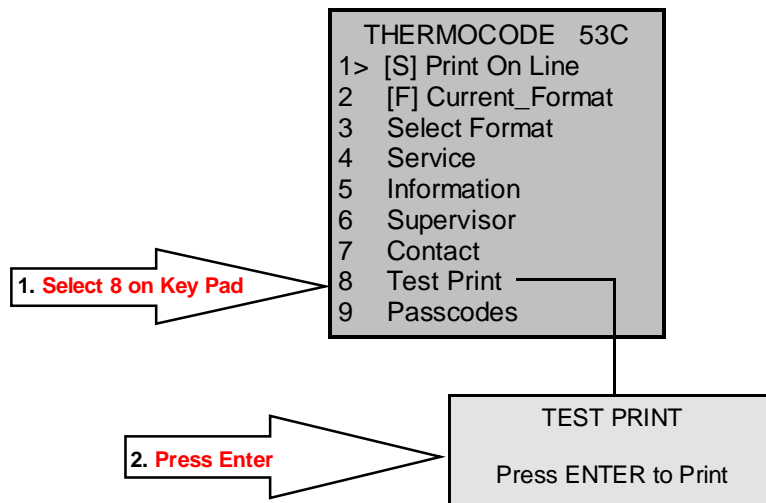

Information Screen

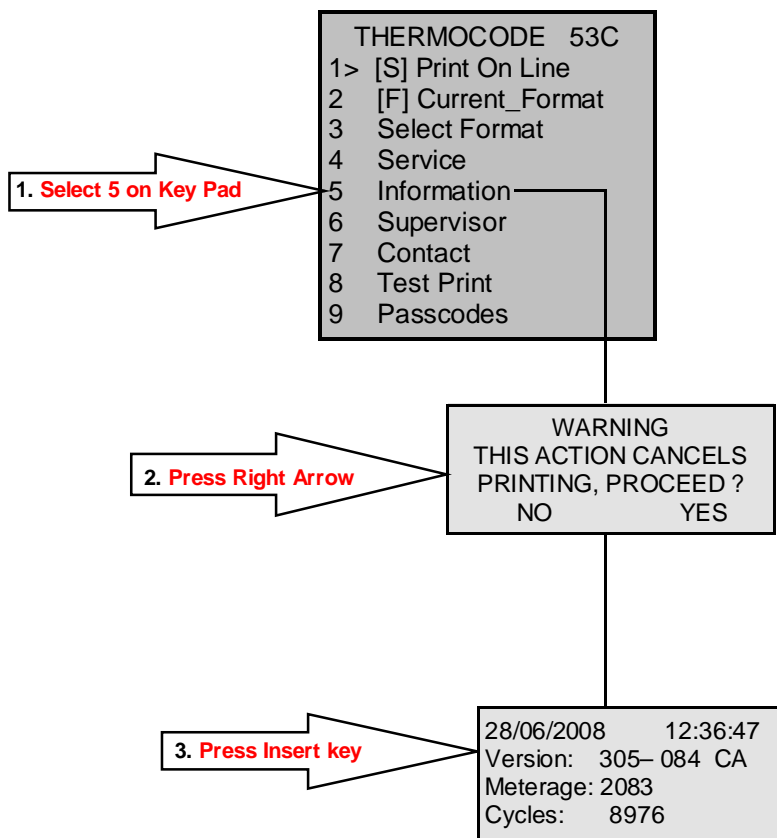

THERMOCODE SERIES 2 RIBBON SPECIFICATIONS

Model	"A" = Width	"B" = Dia Max	"C" = Core Dia	Core Material
53CR	55mm	78mm Ø, (300 Meters)	25.4mm	Cardboard

No leaders or trailers are required

Silicone based "Back Coating" Outside (Low coefficient of friction: $K_d < 0.2$)

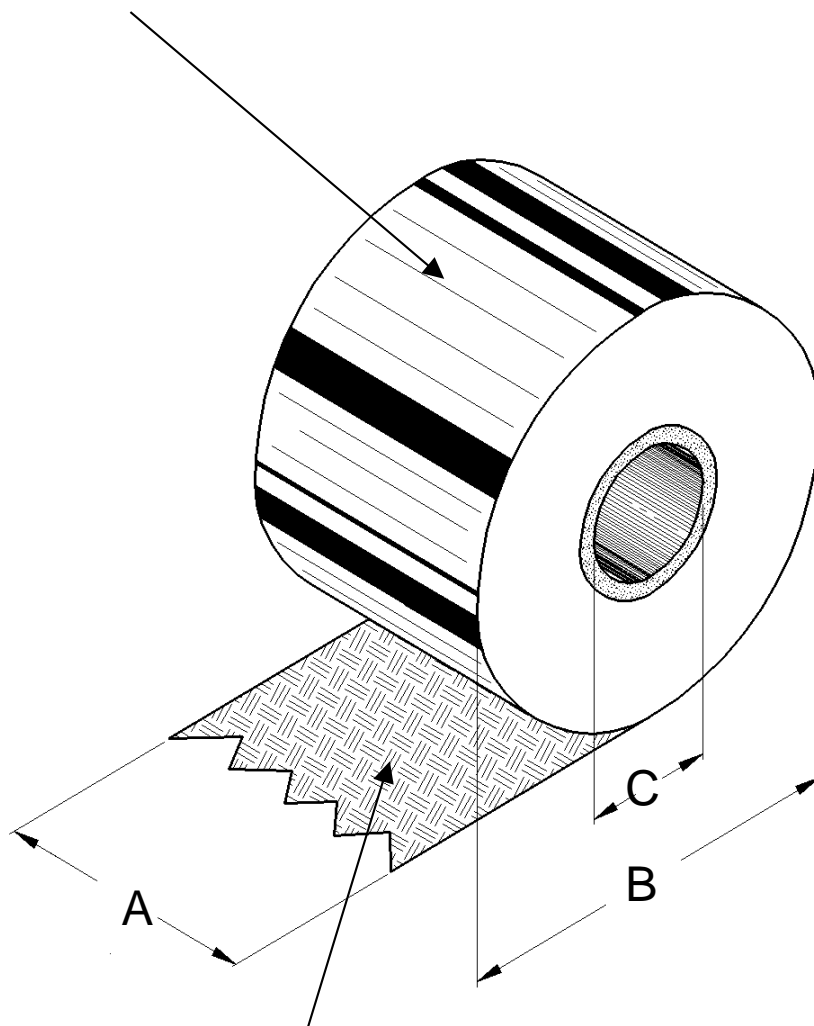

Wax/Resin Pigment Inside Wound

No leaders or Trailers required on Foil.

Open Date Equipment stocks several grades, sizes and colours of Thermal Transfer Ribbon, please call our Sales office for further details specifying the model of Printer that you have. All Ribbons are available on a next day delivery if required.

53CR Ribbon Threading Diagram

ENSURE THE NIP ROLLER IS ENGAGED ON DRIVE ROLLER AFTER RENEWING THE RIBBON

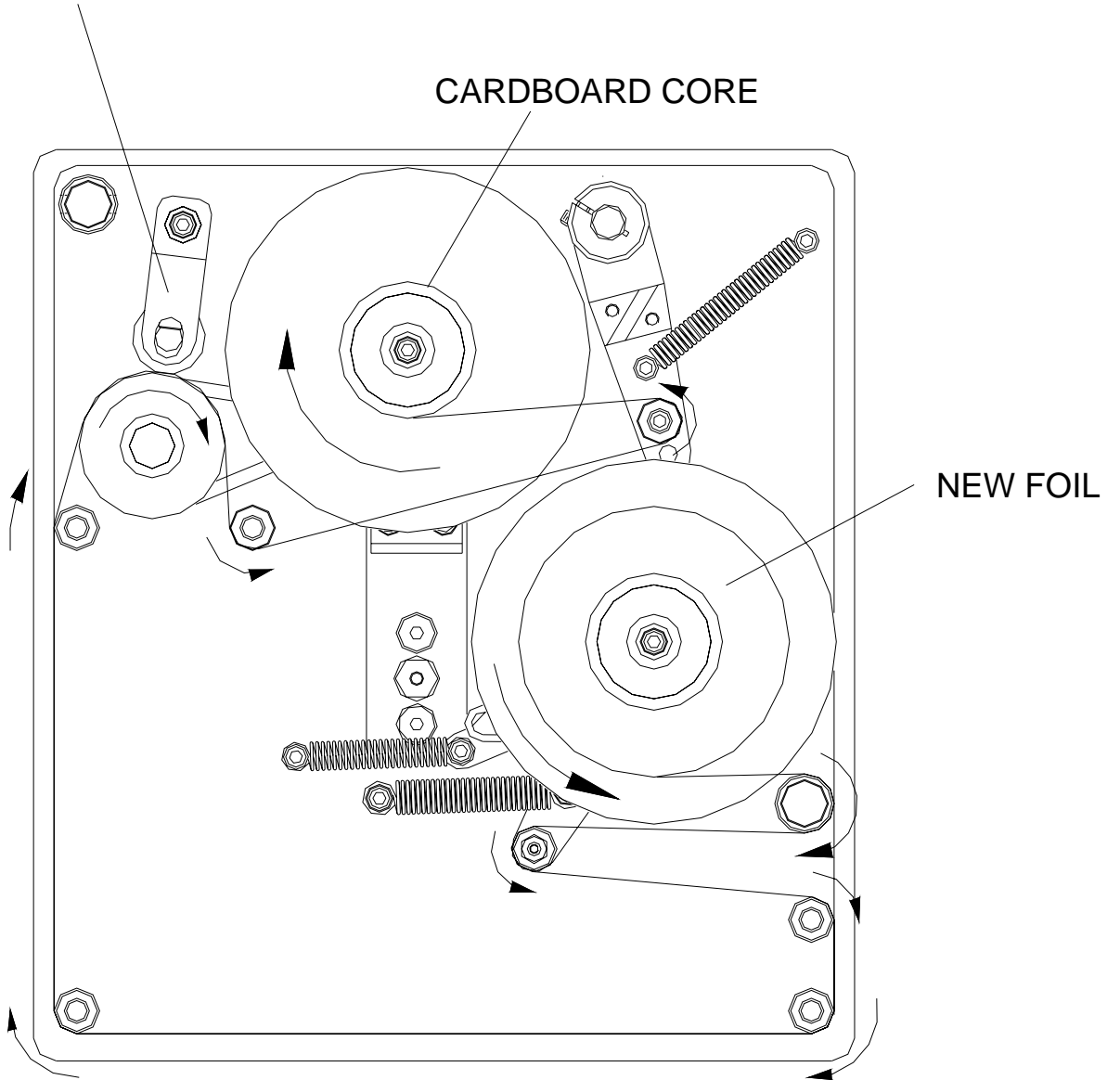

ROUTINE MAINTENANCE (everyday)

1. To simplify cleaning procedures, you may have to remove the printer from the frame.
2. Remove the thermal transfer ribbon from the printer magazine.
3. On the cassette clean all fixed rods and rollers using Isopropanol cleaning fluid and a lint free cloth. (As shown below)

Clean all the parts as indicated

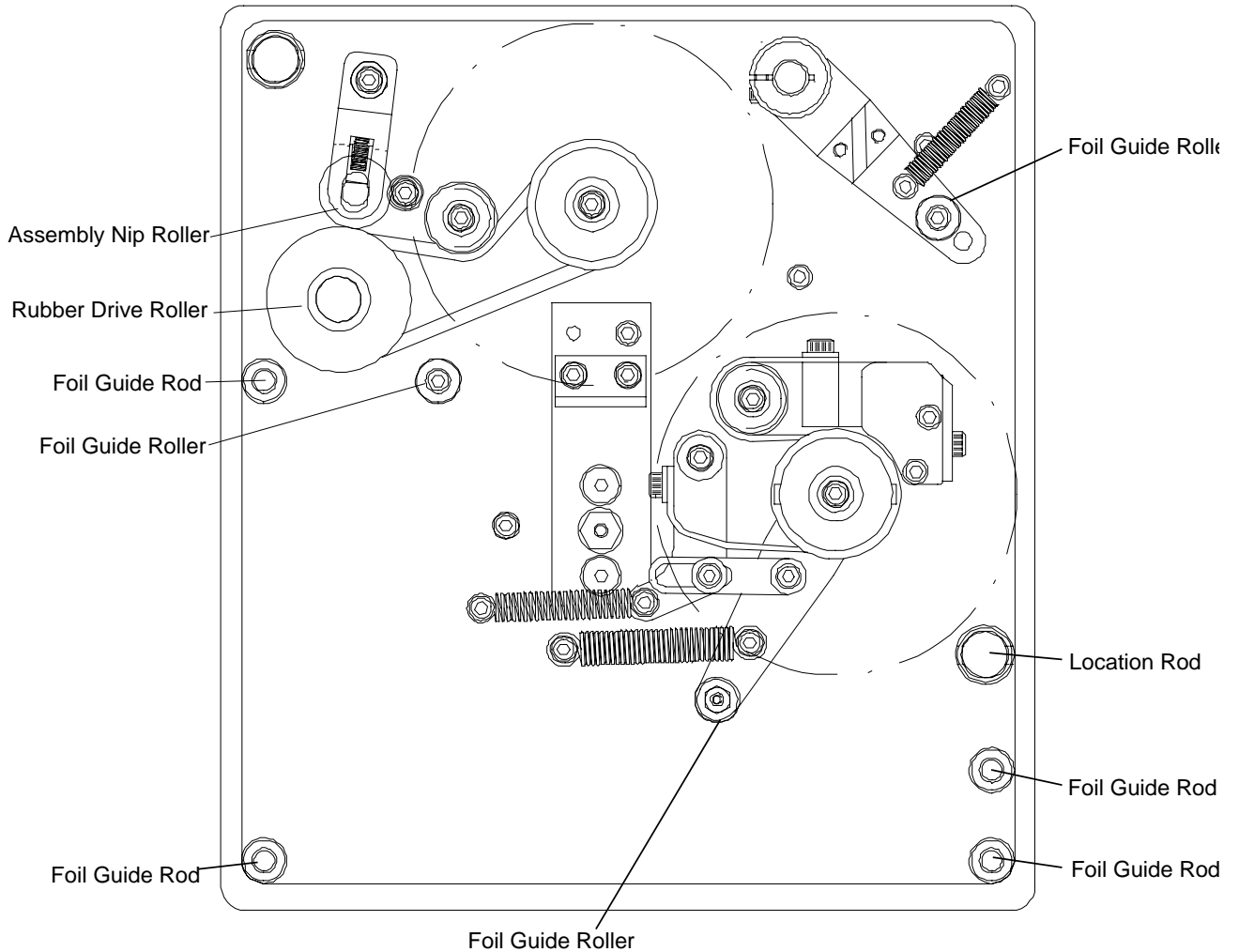

5. On the Lower Roller Unit, clean the rubber roller thoroughly.

ROUTINE MAINTENANCE (Continued)

53CR PRINTER

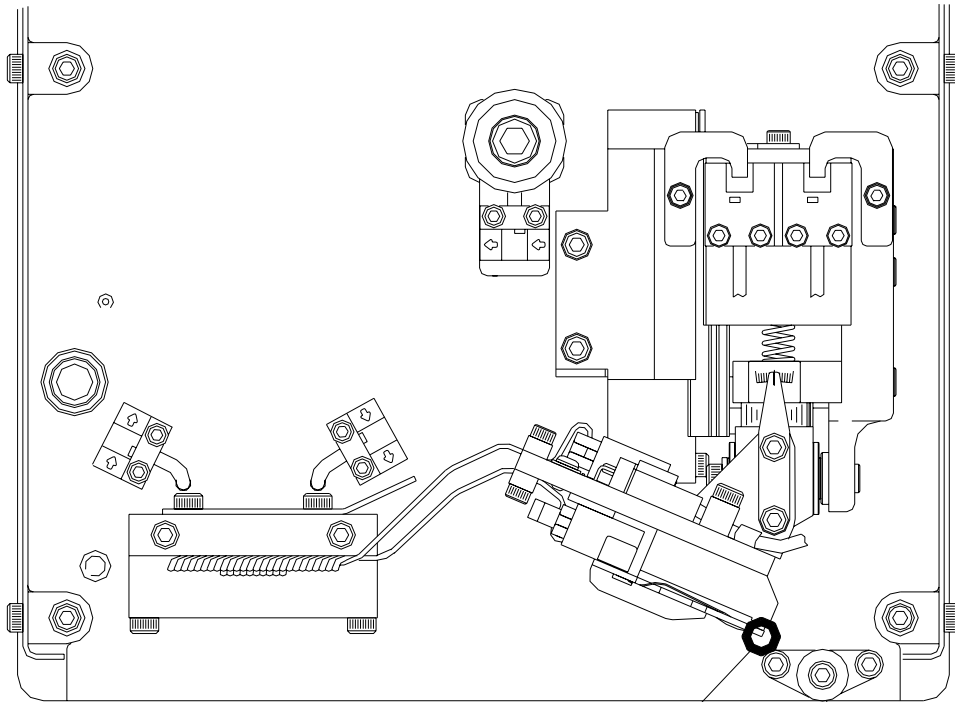

CLEAN PRINTHEAD ALONG FULL LENGTH, WHERE SHOWN

CLEAN FIXED ROLLER ALONG FULL LENGTH

Note!

The Routine Maintenance procedures affect the Standard Warranty terms. If you do not clean the printer regularly, then do not expect to get any warranty on printheads.

If you change a Printhead, do not forget to adjust the alignment of the Printhead to the print roller. As the Printhead angle affects the printing position.

FAULT FINDING (Questions & Answers)

Ribbon Indexing insufficient (Overlapping Prints)

- Q. Cardboard core does not fit the rewind spool correctly, or is missing?**
- A. Fit correct cardboard core, ensure it is located on the spring clips correctly.
- Q. Foil not attached to cardboard core correctly?**
- A. Use adhesive tape to attach the ribbon to the cardboard core and wind on a few turns.
- Q. Printer rods or printhead assembly are dirty, through build up of wax/resin residue?**
- A. Clean printer rods and printhead as described in maintenance section.
- Q. Brake belt on feed spool is damaged, worn or dirty?**
- A. *Renew brake belt.*
- Q. Tension arm spring tension on brake belt not set correctly?**
- A. Adjust brake belt correctly, when functioning correctly the tension arm should be about 6mm from the stop pin.

Ribbon Indexing Excessive

- Q The Format design has a space before printing any characters?**
- A. Change the format design so there is only 1mm from the "X" datum to the first characters to be printed.
- Q Ribbon may be sticking to substrate being printed, and being pulled along?**
- A. Adjust the printhead position from the substrate, possibly the clearance is insufficient and the foil is being indexed along with the substrate. Service Engineer may be required.

Ribbon Breaking or Perforated

- Q. Printhead rods, lower roller or printhead assembly is dirty through build up of wax/resin residue?**
- A. Clean printer and printhead as described in maintenance section.
- Q. Ribbon may be sticking to substrate being printed and being pulled along?**
- A. Adjust the Printhead position from the substrate, possibly the clearance is insufficient and the foil is being indexed along with the substrate. Service Engineer may be required.
- Q. Temperature "BURN" values may be set to high for the substrate being printed?**
- A. Reduce "BURN" values of format to achieve acceptable print quality.
- Q. Ribbon indexing problems, prints overlapping each other, weakening the ribbon?**
- A. See to the section on page 40 for overlapping prints remedies.

Ribbon Tracking

- Q. Printer fixed rods, lower roller or printhead assembly are dirty, through build up of wax/resin residue?**
- A. Clean fixed rods, lower roller and printhead as described in maintenance section.
- Q. Ribbon may be sticking to substrate being printed, and being pulled to one side?**
- A. Adjust the printhead position from the substrate, possibly the clearance is insufficient and the foil is being indexed along with the substrate. Service Engineer may be required.
- Q. Printer may have been dropped, damaging the lower roller or damaged tension arm?**
- A. Call for Service Engineer or send back to manufacturer for checking.

Print Quality Problems

- Q. Print not consistent over printed area?**

- A.** Ribbon not compatible with substrate.

Temperature burn, settings too low. Low printing temperatures can give the effect of the edges of characters appearing faint or ragged.

Damaged or dirty print base or lower print roller, clean and check for any imperfections. Normal Thermocode Series 2 print bases are 45-50 shore hardness rubber, which is bonded to an aluminium backing sheet and then ground. Flatness of this pad or roller is very important, on some labelling machines if the backing web is not aligned correctly it will cut into the print base or actually miss-shape it due to the tension of the backing web.

Printer not correctly mounted in frame.

Printer frame not manufactured to correct dimensions, clearance under printer excessive. See Standard Frame measurements drawings at the end of this manual.

Printhead dirty or pixels burnt out. Clean the printhead and test print on plain fax paper to confirm the condition of the printhead.

Ribbon indexing not enough. See previous page.

Ribbon tracking on printer, causing creasing. See previous page.

Ribbon perforated or broken, see previous page.

Ribbon ink coating inconsistent.

Clearing Printer Errors

All errors that occur within the printer are shown as **“Error”** on the status line of the Mini-Terminal display. To view the actual error press No.1 or the Enter key of the keypad. Errors are shown as text messages along with a numerical number which must be noted if you are requesting a Service visit or assistance.

Once errors have been viewed they can then be cleared, page up to the top of the screen and press **“Enter”** when the cursor is next to the option **“Clear errors”**.

Clearing errors can have two consequences, if the errors are mechanical the error is cleared and the format is retained in the image memory. If the error is a format design problem, as the error is cleared the format will be removed from the image memory.

The only way to correct format errors is to redesign the format this cannot be corrected by adjusting parameters within the Mini-Terminal parameters.

THERMOCODE Continuous Printer (diagnostics sheet 1)

FAULT DESCRIPTION	REMEDY / ACTION
Printer keeps re-booting	Check printer 5 volt supply is adjusted correctly See page 11 & 15
Flashing cursor on mini-terminal screen.	<ol style="list-style-type: none"> 1. Remove the Magazine, and then replace it. 2. Replace display curly cable. 3. Replace display. 4. Replace processor board and re-program.
Error on start up (boot up). X or Y overflow.	<p>If the mini-display shows 53 or 107, with a "0 after it, instead of the model letter?</p> <ol style="list-style-type: none"> 1. Check 10 way ribbon connections, each end. 2. Contact your Supplier, to fix the Printhead problem.
Printhead temperature. (Head Cold Fault)	Change the wider ribbon cable between the printhead and processor board.
Printhead LED stays on. (Power Supply)	Change the 24 Volt DC switching board, See page 15.
No display on the mini-terminal.	<ol style="list-style-type: none"> 1. Check 1.6 amp fuse within power supply. See page 15. 2. Check the ribbon cable, beneath the stepper board inside the power supply. See page 15.
Printhead LED, not working. (Power Supply)	Check the 15 or 20 amp fuse within power supply, located on the 24 Volt DC board. See page 15.
Printing Wavy Barcodes.	<ol style="list-style-type: none"> 1. Brake arm loose on brake on brake lever. 2. Retaining washer loose or missing from foil rollers. 3. Increase the Print height above the substrate.
Ribbon Tracking (movement to one side)	<ol style="list-style-type: none"> 1. Check brake is not set to tight. 2. Check brake arm is not loose. 3. Check any foil guides are not loose or bent. 4. Check Printhead is levelling correctly.
Broken Ribbon Sensor.	Check the brake arm is not loose, and passes through the sensor correctly.

THERMOCODE Continuous Printer (diagnostics sheet 2)

FAULT DESCRIPTION	REMEDY / ACTION
No power to printer / No voltage to power supply	<ol style="list-style-type: none"> 1. Check fuses in mains plug and power supply. 2. Check supply voltage is at source. 3. Check all the fuses in power supply. 4. Check all electrical connections are correct.
Ribbon broken.	<ol style="list-style-type: none"> 1. Replace ribbon. 2. Check brake tension on cassette. 3. Replace or repair thermal ribbon.
Low foil warning.	Replace thermal ribbon on printer, ensure that you press the "yes" key on the mini-terminal after engaging the nip roller, to reset the foil counter.
Count completed.	<ol style="list-style-type: none"> 1. Select another format. 2. Edit quantity via mini-terminal display
No format name displayed on screen.	<ol style="list-style-type: none"> 1. Format has been de-selected. 2. Select a new format.
No font loaded to printer, for format selected.	<ol style="list-style-type: none"> 1. Load the font to printer and select the format again. 2. Load a different format that has printer fonts. 3. Check which fonts have been loaded to printer, by interrogating with the "Codesoft" software
Print on line, awaiting print signal.	Normal condition
Pressure switch fault.	<ol style="list-style-type: none"> 1. Check the mounting frame is not open. 2. Check the gap between printer and print base. 3. Check sensor assembly has not come loose. 4. Check wire crimps and connections. 5. Check LED on sensor activates correctly. 6. Check print base rubber is not damaged or missing. 7. Check pressure setting within format parameters.
Vertical home sensor fault.	<ol style="list-style-type: none"> 1. Check sensor assembly has not come loose. 2. Check wire crimps and connections. 3. Check LED on sensor activates correctly.
Printhead Thermistor fault / disconnected	<ol style="list-style-type: none"> 1. Check ribbon cables are fitted correctly to printhead and interconnect PCB. 2. Faulty printhead, replace.

Error Codes

This file contains a list of error texts and their associated error numbers. The error numbers are displayed **after** the error text, along with the source number, with the exception of the two shown below.

Error Message	Reason	Corrective Measures
Run Program	Firmware corruption	Switch the printer off. Then Reload the firmware.
No Program Loaded	Disconnection on communications lead, when down loading the Firmware. Sending fonts or formats, whilst booting up the printer.	Press the enter key, reset the Baud rate, reset the RTC. Press accept. Switch the printer off. Then Reload the firmware.

Example: Pressure not seen 21, 2266

This is error number **21**, on line number 2266 of the source code file. This line number is only of use to the developers, but is worth recording along with the version of firmware.

Error Number	Error Message	Reason	Corrective Measures
11	Serial port fail	Problem with hardware.	Check cables & connections, if the cables are ok replace the Processor Board.
12	SPY chip fail	1. Failure in writing to the Spy chip from the boards. 2. The Ribbon Cable could be faulty.	1 & 2. Re program or change the Spy Chip Board. If you still have the same Fault Change the Ribbon cable. (14 Days notice See note 1 page 8)
13	SPY buff fail	Wrong Version of Software.	Re program or change the Spy Chip Board. If you have the same Fault Change the Ribbon cable.
14	SPY param fail	Wrong Version of Software.	Re program or change the Spy Chip Board. If you have the same Fault Change the Ribbon cable.
15	RTC fail	Faulty real time clock.	Check the battery 3.6v. Change the Processor Board. (Contact Supplier)
16	DAS can't format	Problem with memory on processor card.	Change the Processor Board. (Contact Supplier)
17	Head overheated	1. Thermistor failed on Printhead. 2. The Ribbon cable could be faulty.	1 & 2. Change the Print Head. If you still have the same Fault Change the Ribbon cable. Then Refit the original Print head
18	Head Cold	1. Thermistor failed on Printhead. 2. The Ribbon cable could be faulty.	1 & 2. Change the Print Head. If you have the same Fault Change the Ribbon cable. Then Refit the original Print head.
19	Too fast 1	Web speed too fast for printer.	Reduce web speed.
20	Too fast 2	Web speed too fast for printer.	Reduce web Speed.
21	Pressure not seen	1. Pressure sensor Failed or dirty. 2. Frame open or Print pad missing 3. Incorrect Motor steps to the Print Pad. Occurs on Format Download & when printing. 4. Low voltage. Under 5 VDC to the Printer.	1. Clean or replace the sensor. 2. Switch the Printer off. Close the Frame or replace the Print Pad. Reboot the Printer. 3. Clear the error. Carry out some test prints. 4. Check the voltage and adjust to 5.1 volts. Fault 155 "No press confirmed" Will also be shown. Carrie out the above checks, when both faults are shown.
22	End sensor fail	The Print head has not seen the end sensor	1. Clean the Sensor or change if failed. 2. Check the ribbon cables are not fouling the guard of the Printer. Display may read as a 107S when the Printer is actually 107M.

Note:- The first error shown with in the Mini Terminal is the fault. Any other error faults shown on the display, maybe generated because of this fault shown.

Error Codes

Error Number	Error Message	Reason	Corrective Measures
23	Serial port overrun	Problem of serial port handshake.	Check your Com Port Setting. Try new serial port cable. If this makes no difference change the Processor Boards.
24	Serial buffer overrun	Problem of serial port handshake.	Check your Com Port Setting. Try new serial port cable. If that makes no difference change the Processor Boards.
25	Start sensor too close.	The start sensor is too close to the Print head	Move the start sensor way from the Print head.
26	Sys param unknown	Requested or sent a unknown System Variable	Request or send the correct one.
27	Relay delay out of range	Problem with variable SYSREDEL	Check the setting in the Mini Terminal. Service menu no 6, menu no 3 Delay (Inhib delay)
28	Format param unknown	Format Parameters incorrectly entered in the format.	Correct the Parameters. The fault can only be created using Dos.
29	Sys string long	System Variable string has an incorrect entry. .i.e. 13 months instead of 12 entered in SYSMON etc.	Correct the System Variable and resend to the Printer.
30	List type unknown	Z? Requesting a nonexistent system variable	Clear the error. Enter the correct request code.
31	Delete type unknown	Deleting an Unknown request.	Incorrect escape code used when using the delete command.
32	List file unknown	Requesting a non existent Format Font etc.	Clear the error. Request the correct Format or Font etc.
33	Delete file unknown	Deleting an Unknown Format File.	Typing error or the Format, Font etc is not in the Printer.
34	Bad line	1. Communication Lead faulty. 2. Codesoft has been Networked	1. Check the communications lead is plugged in on the Computer & Printer. Check the lead for any dry joints. 2. If not Networked, check Codesoft is not set on Network in the Advanced menu.
35	Bad Format Line	Format information Incorrect	Correct the format design.
36	Format line too long	1. Text line too long maximum of 149 character & spaces. 2. The text box used in Codesoft is larger than the required text. With no carriage return. 3. Codesoft, Word wrap has been checked. 4. Baud rate incorrect	1. Reduce the text line. 2. Reduce the text box to the size of the text length. 3. Uncheck the word wrap in Properties & Paragraph. 4. Check the Baud rate with in Codesoft.
37	Local graphic error	Problem with local graphic in a format.	Re-load format, or check graphic.
38	Graphic file missing	Format sent to the Printer with out the Graphic File. Global graphic has been deleted from the Printer.	In Codesoft Printer settings, General, Reload image at next print job should be checked. (Box ticked) Correct the Format Design & resend to the printer.
39	Too many local graphics	Too many local graphics designed with in the Format.	Reduce the number of graphics with in the Format design.
40	Too many graphics	Too many local and global graphics loaded to the Printer	Reduce the number global graphics.
41	Cant update format not selected	The Format has not been selected for Printing.	Select the format you wish to send Modified data only to.
42	Box too narrow for line width	Box design incorrect	Correct the Format design. The fault can only be created in Dos.
43	Box too low for line height	Box design incorrect	Correct the Format design. The fault can only be created in Dos.

Note:- **The first error shown with in the Mini Terminal is the fault. Any other error faults shown on the display, maybe generated because of this fault shown.**

Error Codes

Error Number	Error Message	Reason	Corrective Measures
44	Line/ box too wide	Box design incorrect	Correct the Format design. The fault can only be created in Dos.
45	Rotation out of range	Incorrect Rotation set in the Format should be 0,1,2 or 3	Correct the Format with correct rotation. The fault can only be created using Dos.
46	Scale factor wrong	Graphic Scaling factor incorrect should be 0,1 or 2	Correct the Format design.
47	Bar lines overflow	Incorrect barcode design.	Correct the barcode design. The fault can only be created in Dos.
48	Bad bar style	Selected a non-supported Barcode type.	Check the type of Barcode required. The fault can only be created in Dos.
49	Bad bar width	Bar width larger than 5 or less than 2.	Bar width Maximum 5, Minimum 2. The fault can only be created in Dos.
50	Bad bar ratio	Ratio within the Barcode Format design incorrect. Available Ratios are 0 =3,1= 2.5 & 2= 2	Correct the Format design. The fault can only be created in Dos.
51	Bad bar human	Human readable is larger than 1	Human readable maximum 1 Minimum 0. The fault can only be created in Dos.
52	Bad bar csum	Check Digit value larger than 1	Check digit Maximum 1, Minimum 0. The fault can only be created in Dos.
53	Bad bar speed	Incorrect Speed flag. Should be Zero	Correct the Barcode design. The fault can only be created in Dos.
54	Bad bar data	Barcode data to many or few digits for the barcode type. Check Type of Barcode, whether numerical or Alphabetical or both.	Change the number of digits to suit the Barcode type, check the style of barcode and the data needed.
55	Graphic To Wide	Graphic too wide for the printer. Graphic file corrupted?	Resize or replace the graphic
56	X underflow	Format design is out side the Print area, on the left side of the "X" axis.	Move the Format design to be with in the Print area.
57	X overflow	Format design is out side the Print area, on the right side of the "X" axis.	Move the Format design to be with in the Print area.
58	Y underflow	Format design is out side the Print area, at the top of the page on the "Y" axis.	Move the Format design to be with in the Print area.
59	Y overflow	Format design is out side the Print area, at the bottom of the page on the "Y" axis.	Move the Format design to be with in the Print area.
60	Timeout in Binary	1. Incorrect Baud Rate Set 2. Noise on the Communication lead 3. Incorrect Network number set. (Network printers only)	1. Check the Baud Rate 2. Check the communication lead. 3. Check the Network number.
61	Timeout in format	1. Information in the Format Design, missing or incorrect 2. Network number set in the Printer. But not in Codesoft.	1. Correct the Format Design. Other error generated during the download of the format or fonts. 2. Set the Printer Network number to Zero if no Network. Then re-boot the Printer. If networked, set network number in Codesoft.

Note: - *X and Y overflows. Do not use Arial Black type font. The Codesoft WYSIWYG is incorrect when using this Font.*

Note: - *The first error shown with in the Mini Terminal is the fault. Any other error faults shown on the display, maybe generated because of this fault shown.*

Error Codes

Error Number	Error Message	Reason	Corrective Measures
62	Format not found	Requested a Format not downloaded to the Printer.	Requested the wrong Format name or the Format is not Loaded to the Printer.
63	Erasing font in use	Deleting a Font when used in the current format.	Stop Printing, delete the Font. Re-select a format.
64	Reverse field wrong	Reverse image text should be 0 or 1 (not supported)	Correct the field.
65	Proportional field wrong	Incorrect Proportional field. Value = 0 or 1	Correct the value. The fault can only be created in Dos.
66	Text field overflow	Maximum Text in variable = 0 to 59	Reduce text length in variable to less than 60.
67	Text lines overflow	Too many text lines with in the designed format	Reduce the amount of Text. Maximum of 120 lines.
68	Text fields overflow	Too many text fields in the format.	Reduce text fields in format to be below 150.
69	Too many counters	Format design has too many counters maximum of 20 counter fields.	Reduce the number of counter fields with in the Format design.
70	Too many Variable	Too many variable with in the format.	Reduce the number of variables.
71	Missing Variable	The variable has not loaded with the format	Correct the format design
72	Variable out of Limit	Variable field with high and low limits	Correct the variable field. The fault can only be created in Dos.
73	Global counter too wide for field	Incorrect counter field design	Correct the counter field. Enter a Padding Character in the Counter Field. Found in "Output" Enter "0" (Zero).
74	Local counter too wide for field	Incorrect counter field design	Correct the counter field. Enter a Padding Character in the Counter Field. Found in "Output" Enter "0" (Zero).
75	Font missing	The Font required is not loaded to the Printer	Load the appropriate Font to the Printer.
76	Font size unavailable	A Bit Map Font (SFP) has been down loaded. The Format design has an incorrect point size.	Correct the Format design. Or load the Bit Map font required.
77	Font file problem	Bit map font loaded to the Printer with out a font size.	Delete the font, correct your font file then reload the font to the Printer. Enter the font size The fault can only be created using Dos File to download fonts.
78	Font code problem	Corrupted Font File.	Delete and then replace the corrupted Font.
79	Time out of range	Incorrect time form sent to the Printer. e.g. 2530	Correct the field.
80	Date out of range	Incorrect date form sent to the Printer. e.g. 321002	Correct the field.
81	Can't update variable	Variable has not been designed in the format or is missing.	Correct the format Design.
82	Global variable unknown	The Global variable has not been loaded to the Printer. Or has been deleted.	Resend the Global variable to the Printer.
83	Daysave error	Incorrect information entered in the daylight save field.	Correct the Daylight saving field.
84	Sys param out of range	Changing a System Parameter with a value out range.	Correct the parameters with in your format design The fault can only be created using Termode or Service.
85	Too Many Horizontal Steps	1. The Home offset set too high for the size of Printer. 2. The Printer has not seen the End or has sensor failed. The one to the right of the Printer.	1. Reduce the Home offset. 2. Check the sensor is clean & working. The ribbon cables are not fouling the guard of the Printer. Top line may read as a 107S when the Printer is a 107M.

Note:- The first error shown with in the Mini Terminal is the fault. Any other error faults shown on the display, maybe generated because of this fault shown.

Error Codes

Error Number	Error Message	Reason	Corrective Measures
86	Format has no image	The Format has not been generated for the Image Memory. When other Faults have occurred.	Rectify the faults within the Format.
87	Line with no network number	Format sent to the wrong network number.	Check the Network numbers are correct.
88	Line with unwanted network number	Network number selected in Codesoft. Printer has no Network number set.	Printer settings, then Advanced. Uncheck the "Network" box. Then click OK.
89	Burn file corrupt	Bad date written in the Burn File before being compiled, or corrupted on send.	Check & correct the Burn file
90	Burn file to long	Incorrect burn file design.	Check & correct the burn file.
91	Burn duty too high	<ol style="list-style-type: none"> 1. The Burn duty in the Format has been set too high. 2. The Burn duty in Set Parameters is too high. 3. The Burn duty is close to or set on the upper limit and the room or head temperature has raised. 	<ol style="list-style-type: none"> 1. Reduce the Burn duty within the Format and resend to the Printer. Or Change with in the Mini Terminal. 1. 2 & 3. Reduce the Burn duty within Set Parameters.
92	H table overrun	Internal software error.	Report, with format to Open Date UK
93	R table overrun	Internal software error.	Report, with format to Open Date UK
94	V table overrun	Internal software error.	Report, with format to Open Date UK
95	Bad case	Internal software error.	Report, with format to Open Date UK
96	Can't write parameter update	Internal software error.	Try INEW, then report, with format to Open Date UK
97	Can't read parameter update	Internal software error.	Try INEW, then report, with format to Open Date UK
98	Bad file copy	Internal software error.	Try INEW, then report, with format to Open Date UK
99	Can't open temp FMS	Internal software error.	Try INEW, then report, with format to Open Date UK
100	Can't open parameter file	Internal software error.	Try INEW, then report, with format to Open Date UK
101	Can't open format file	Internal software error.	Try INEW, then report, with format to Open Date UK
102	Get Character fail	Internal software error.	Try INEW, then report, with format to Open Date UK
103	CM_ALLOCATE fail	Internal software error.	Try INEW, then report, with format to Open Date UK
104	FM_ALLOCATE fail	Internal software error.	Try INEW, then report, with format to Open Date UK
105	Write to read only store	Internal software error.	Try INEW, then report, with format to Open Date UK
106	Read only store missing	Internal software error.	Try INEW. Try reloading .HEX file, report, with format to Open Date UK
107	ASY_STAT bad	Internal software error.	Report, with format to Open Date UK
108	Print On Line	Printer waiting a print signal.	(No error)
109	Loading Format	Format being loaded to the image memory.	(No error)
110	Creating Image	Image being created within the image memory.	(No error)
111	Printing	Only seen when printing large formats at low speed.	(No error)

Note:- The first error shown with in the Mini Terminal is the fault. Any other error faults shown on the display, maybe generated because of this fault shown

Error Codes

Error Number	Error Message	Reason	Corrective Measures
112	Cassette Off	Cassette is Off. Or Possible sensor fault.	If the Cassette is on the printer, but the fault Cassette Off message appears. Check the Cassette release & the Cassette sensor.
113	Ribbon break	Burn too high, ribbon settings incorrect	Reduce the Burn. Check the ribbon settings. Check the Cassette brake arm tension.
114	Initialising	Printer Boot up sequence.	(No error)
115	Find pre print	Pre print height. Default 1mm. User selectable	Service Menu, No 3, Datum. 1 to 9mm (No error)
116	Parking	Printer Boot up sequence & after replacing the Cassette.	(No error)
117	Error	You have an error	Press the enter key, scroll down to the last fault in the list.
118	Printing paused	Operator selected Printing paused.	Deselect Paused printing
119	Count Completed	Selected number of printer counts completed.	Reset the counter field. Will occur after one print if Infinite print is not selected within Codesoft.
120	Ribbon Low	The ribbon is low, or incorrect ribbon settings	Replace the ribbon. Check the ribbon settings 50, 300 or 500mm
121	Print Off Line	No format loaded to the Printer image memory's	Select or download a format
122	Prints too close for high speed	When distance delay expired, the printer was still printing the last image.	Try decreasing, the distance from the print registration sensor to the printer.
123	Trigger whilst printing	A print signal sent to the Printer when Printing.	Try decreasing, the distance from the print registration sensor to the printer. Check the shaft encoder. (See fault 125)
124	Trigger no profile	Software error.	Try reloading the format. Report to Open Date.
125	Too many triggers	Too many Print signals sent to the Printer.	Check the Encoder for mechanical faults. Encoder drive wheel slip, mounting brackets etc. Check the electrical connections. Reduce the distance of sensor from printer.
126	Too many shift codes	Too many shift codes entered in the format design	Reduce the number of shift codes maximum of 24
127	Home offset too big	Home offset too large within the format design	Reduce the Home offset & resend the format to the Printer.
128	Bar too large	The barcode is too large for the printer to generate	Try reducing the barcode bar width
129	Can't open fixed config	Major Internal software error.	Try reloading the Firmware. Contact Open Date UK
130	Can't open new config	Major Internal software error.	Try reloading the Firmware. Contact Open Date UK
131	Failed config read	Major Internal software error.	Try reloading the Firmware. Contact Open Date UK
132	Command not supported	Major Internal software error.	Try reloading the Firmware. Contact Open Date UK
133	Can't load file	Major Internal software error.	Try reloading the Firmware. Contact Open Date UK
134	Nip Roller open	53E Nip roller is open	Close the nip roller. If you cannot clear the error check the nip roller sensor & the 5 volts.
135	Not Used.		
136	Trigger whilst Printing	A print signal sent to the printer whilst updating the variable fields.	Try decreasing, the distance from the print registration sensor to the printer. Check the shaft encoder. (See fault 125)
137	Disk Full	Too many Formats loaded to the Printer. (Printer RAM Disk)	Delete some formats from the Printer Memory.
138	SPY chip fail	Reminder Message	After 14 days the printer will stop printing. Change the print head. See note 1 Page 7

Note:- The first error shown with in the Mini Terminal is the fault. Any other error faults shown on the display, maybe generated because of this fault shown.

Error Codes

Error Number	Error Message	Reason	Corrective Measures
139	Print Before image update	The Printer Image memory has not updated the variable information sent to the printer, usually from a data base (UPMODE 3)	Ensure the update is sequenced correctly.
140	Day/Month offset wrong	Day offset entered with a month offset	Correct the formats design. Remove the day offset if a month offset is required. You cannot use both types of offset at once.
141	Comm output timeout	Printer port timed out.	Clear the error. Then resend the data if required. If the Printer has locked up, Reboot the Printer.
142	Printer Locked	Variable CFRPT2 has been set to 2.	You cannot send any formats or fonts to printer when locked. Clear the error, unlock the Printer then resend the format or font.
143	IP_SMALL_BUFF TCP/IP	Internal error	Try reloading the Firmware. Contact Open Date UK
144	LOCKED	Incorrect use of CFRPT2	Correct the way you using of CFRPT2
145	Serial Line overflow	Using the "0Y" command more than once. Returns variable data to a computer, using UPMOD 4 & UPMOD 5	Correct the format design and re send too the printer.
146	Variable type unknown	Trying to create an un-recognizable variable (Not a counter or date)	Recreate the variable the correct way. Recognized by our Printers
147	Var File	Trying to use a file type variable and cannot open the File with the data	Correct the variable file and resend to the Printer
148	Comtrig invalid	Invalid field entry in the variable SYSCOMTRIG	Correct the data entered in the SYSCOMTRIG field.
149	Comtrig loop too small	The distance between the formats is too small.	Increase the distance between the Prints in SYSCOMTRIG
150	Triggers /image don't match	SYSCOMTRIG is in correct, doesn't match the formats	Correct the SYSCOMTRIG or the number of formats required for printing.
151	Using COMTRIG without SYSILEN	No Value set in SYSILEN	Send the length of the largest image to be printed. The value is in millimetres.
152	Multi Image select invalid	Valid Image memories are W0X, W1X, W2X. X being Image number	Two or more image memory numbers are the same. Correct the Image memory number. See document Multi Printing for Continuous & Intermittent Printers.
153	No image selected with SYSILEN	SYSILEN has no image memory address.	The SYSILEN has not been allocated an image memory address. (ILEN ,00,01,02 etc)
154	COHDEL to big	COHDEL is set to large in relation the Print Height & Pressure	Reduce COHDEL. Then clear the error Max value is dependent on Print head height. This is measured in steps.
155	No Press confirmed	No pressure confirmed. Internal software error.	Pressure not seen in the internal software loop when starting to print. To indicate the difference between a pressure or pressure sensor fault.
156	Bad PCX	PCX graphic error	Change or modify the graphic and resend to the printer.
157	Counter field CINIT	Counter fields not recognised after installing new firmware.	CINIT the printer then reload the fonts and formats
158	Speed to slow	Variable type MCPSLOW is set to 1	The parent machine speed is the same as or slower then value set in MCSPEED

Note:- The first error shown with in the Mini Terminal is the fault. Any other error faults shown on the display, maybe generated because of this fault shown.

Error Codes

Error Number	Error Message	Reason	Corrective Measures
5007 5008 5009 5010	Open Date Loading Error	1. Noise down the Communication Lead i.e. Sending a Format or Font when the Printer is booting up. 2. Also Booting your Computer & Printer at the same time	1. Do not send to the Printer when booting up. Other than Firmware. Reboot the Printer. 2. Boot the Computer Or Printer one at a time. Not both together. Disconnect the Com's Lead from the Printer and reboot the Printer.
5011	Loading Error	Baud rate incorrect	Check baud rate is same on computer and printer.

Note-: *The first error shown with in the Mini Terminal is the fault. Any other error faults shown on the display, maybe generated because of this fault shown.*

Note 1: - **Spy chip fail**. When this message first appears this will read "**SPY chip fail 12, 34,14**"
This will allow the printer to run for 14 days decrementing each day to 0.
On the 14th day the message will read "**SPY chip fail 12, 2233, 0**"

Everyday you will get an error message at approximately midday. This will happen until the fourteen days are expired, or you change the Printhead.

For updates for the above Error Codes, refer to our Technical Web Site: - <http://www.opendateinfo.com/>

Automatic Burn Compensation As Speed Changes

The modifications that have been included with the software, automatically adjust all the Printhead CONT lines percentage values for different printing speeds. Nominally a speed of 100mm/sec is specified for all formats, and the burn values are automatically adjusted as the speed changes.

Software Advantages

1. Longer printhead life (lower initial power settings).
2. Improved quality of print (even density of image).
3. Automatic burn adjustment at different speeds (speed compensation).

Automatic Speed Compensation

Please see attached speed compensation chart (below). This will give a guide as to the proposed values for printing onto various materials using different thermal transfer ribbons.

Speed Compensation Chart

Use the values below to configure your format ready for printing, the burn values are only a general guide and will most probably need changing to suit your material to be printed.

Once the image density is correct, as the print speed changes burn values will be automatically adjusted to suit.

Please remember for specific Ribbons you may have to alter the ribbon compensation value (SYSRIBTFR) to correct the burn values as the Printhead is warming up. (see escape code manual)

Material description	Proposed value
Print Speed (Standard for all formats)	100mm/sec
Maximum Burn Value (Nominal)	303µsec
Polyethylene type Material (Wax/Resin Foil)	180µsec
Polyester type Material (Wax/Resin Foil)	200µsec
Label type Material (Wax/Resin Foil)	240µsec
Polyethylene type Material (Resin Foil)	260µsec
Polyester type Material (Resin Foil)	240µsec
Label type Material (Resin Foil)	260µsec
Thermal Label (Direct thermal)	170µsec

53CR MAGAZINE SPARES

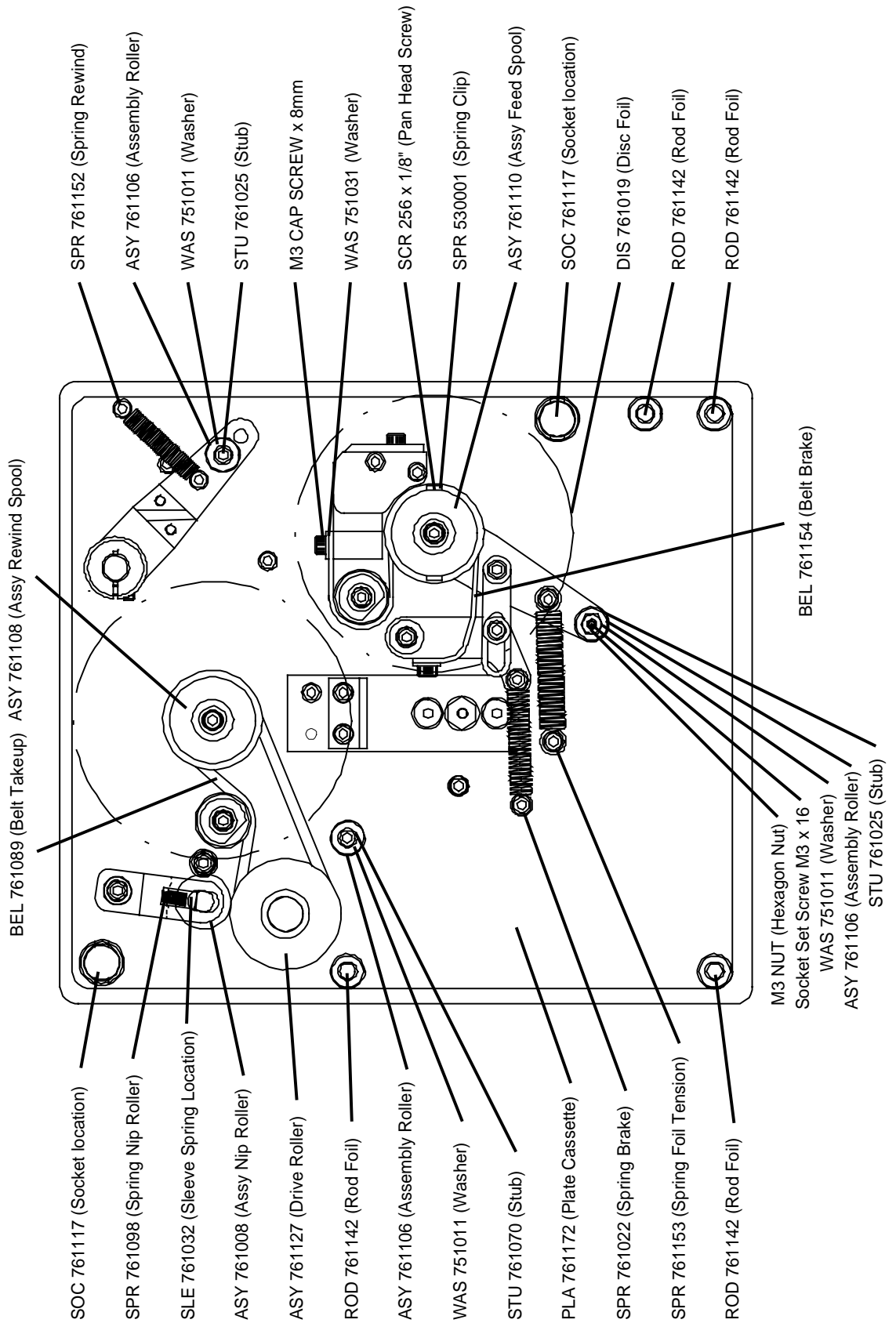

THERMOCODE SERIES 2 (model 53CR dimensions)

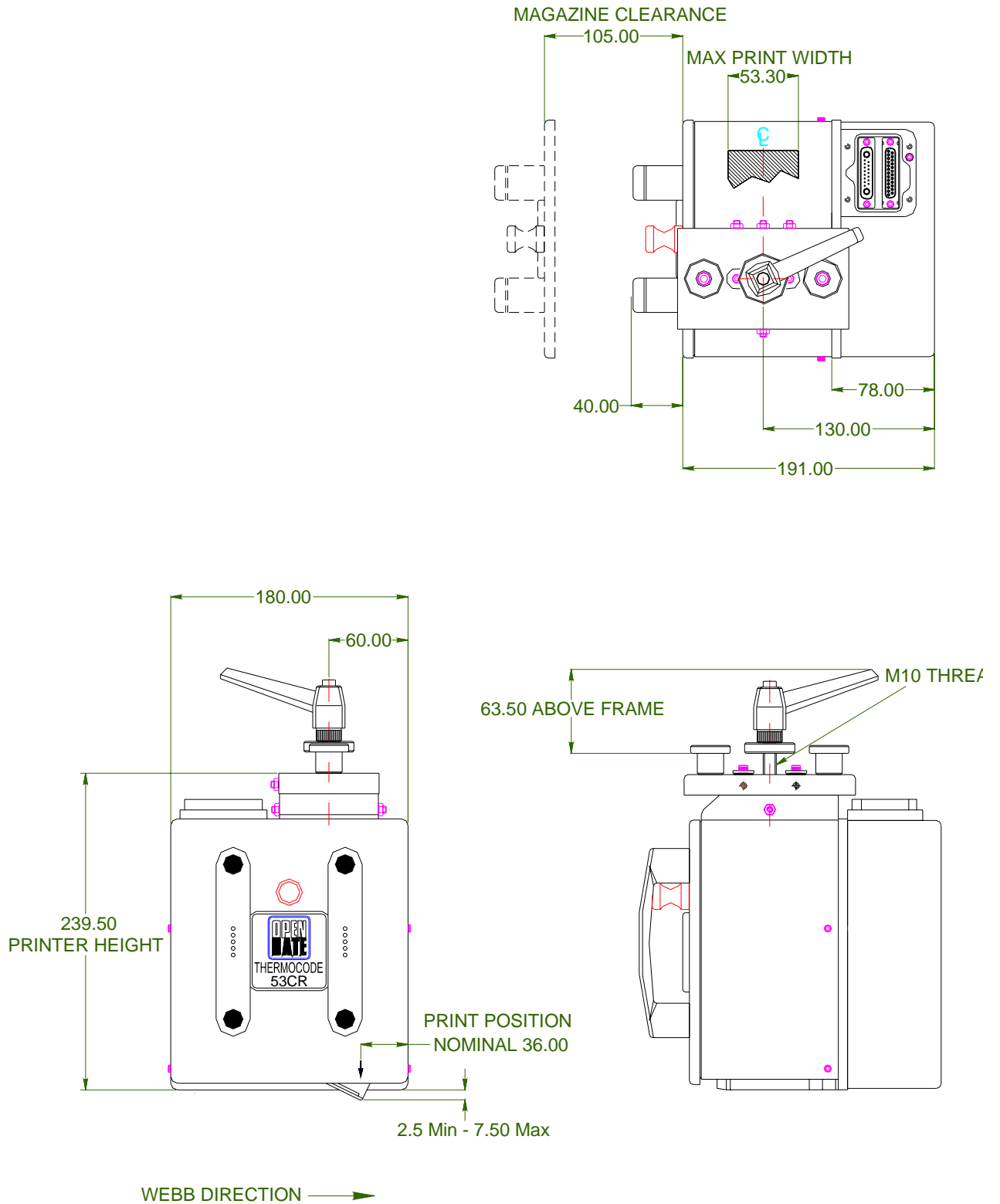

53CR Standard Frame Dimensions

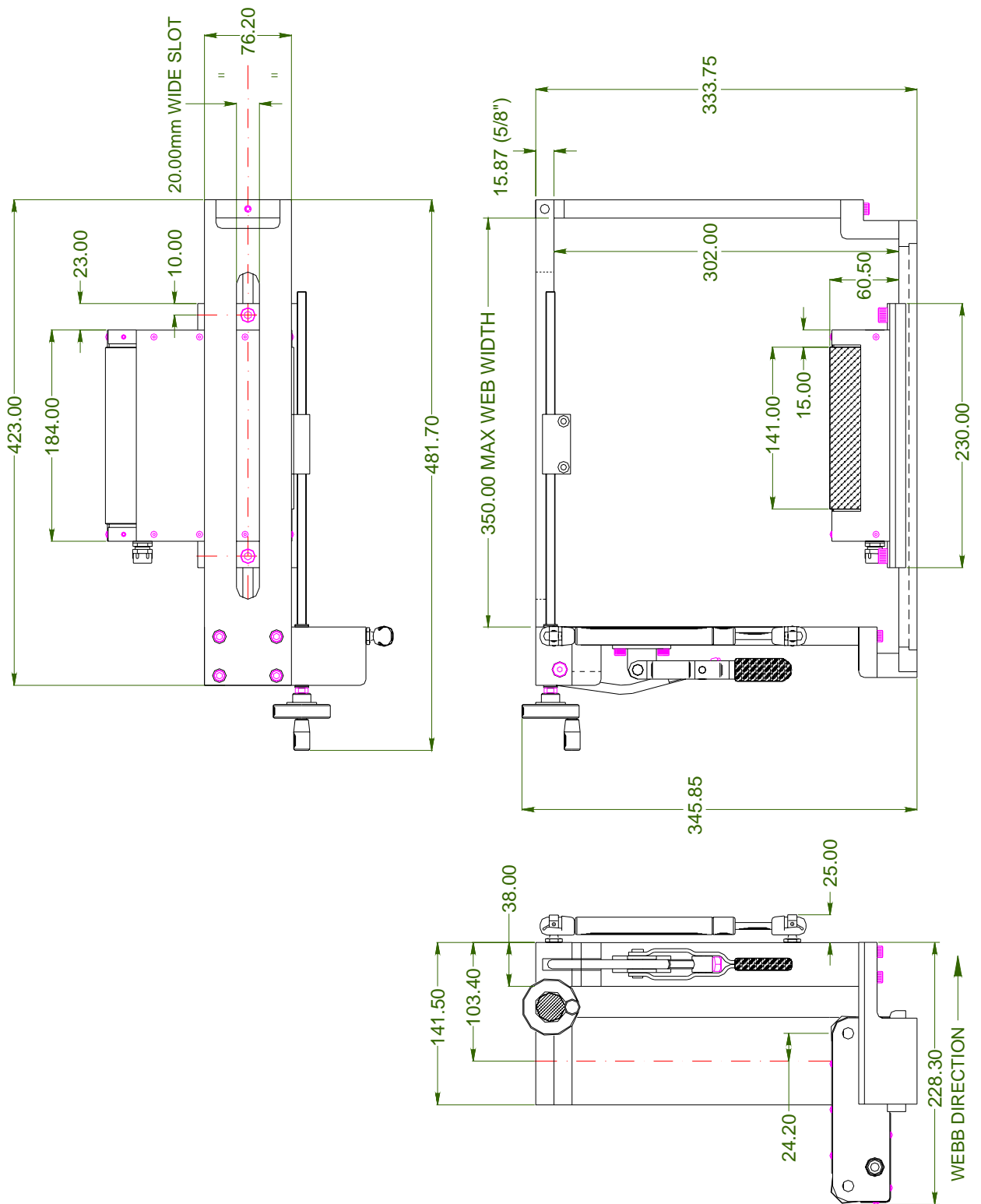

53CR Lower Roller Unit Dimensions

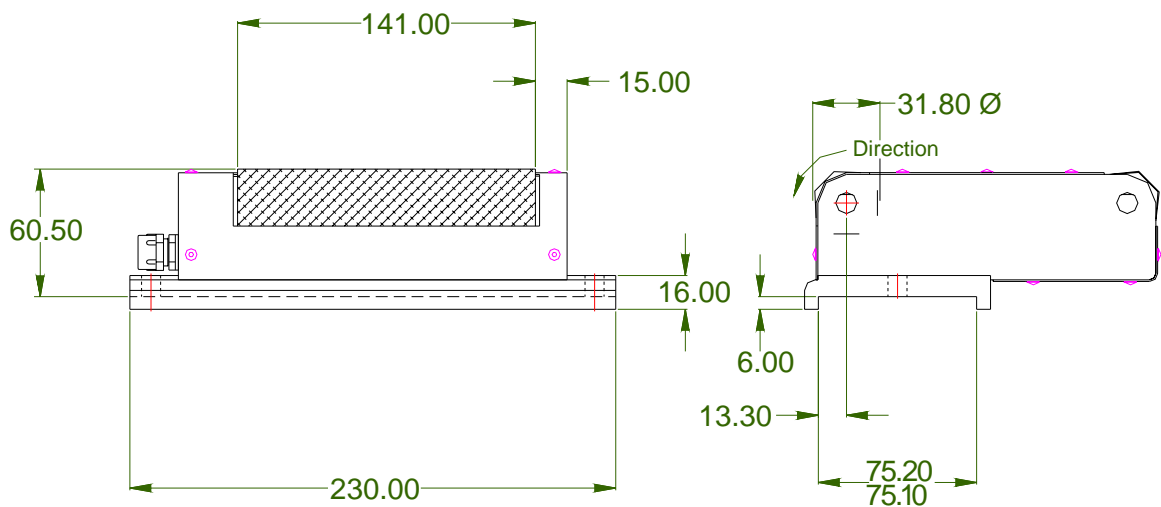
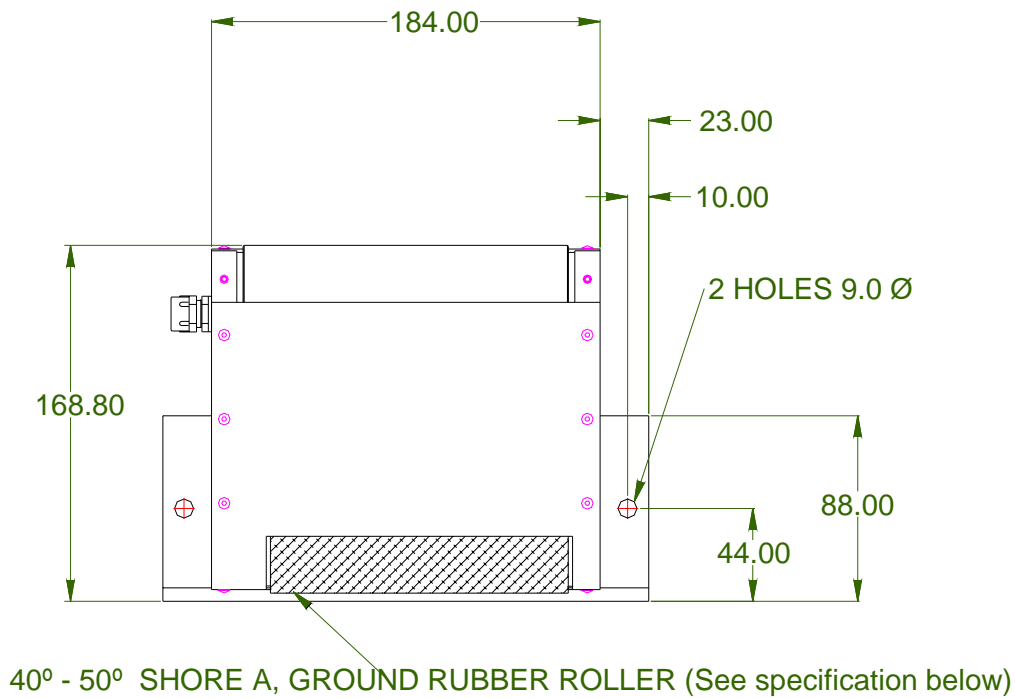

Rubber Roller Specification

Hardness: "40 - 50 Shore A" Silicone Rubber.

Thickness: - Minimum 4.00mm Silicone Rubber bonded to the roller.

Flatness: - Supplied with ground surface, Flatness tolerance -0.05mm to +0.05mm

53CR POWER SUPPLY (Dimensional & Installation details)

Mains Cable Connections:-

Brown = Live
 Blue = Neutral
 Green/Yellow = Earth

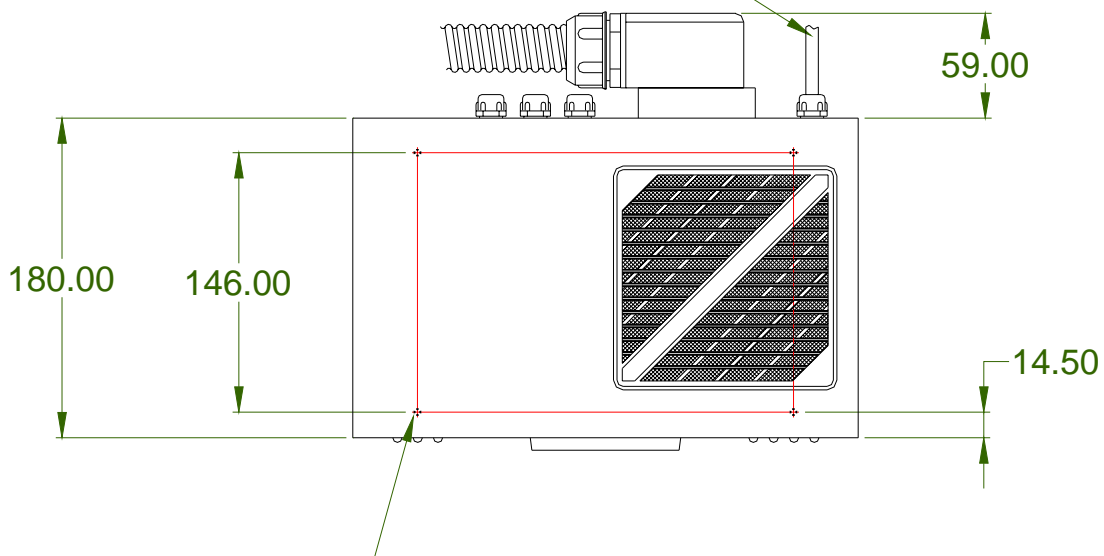

4 OFF FEET POSITIONS, CAN BE USED FOR MOUNTING
 (M4 SCREWS) MAX THREAD LENGTH INSIDE POWER SUPPLY 10.0mm

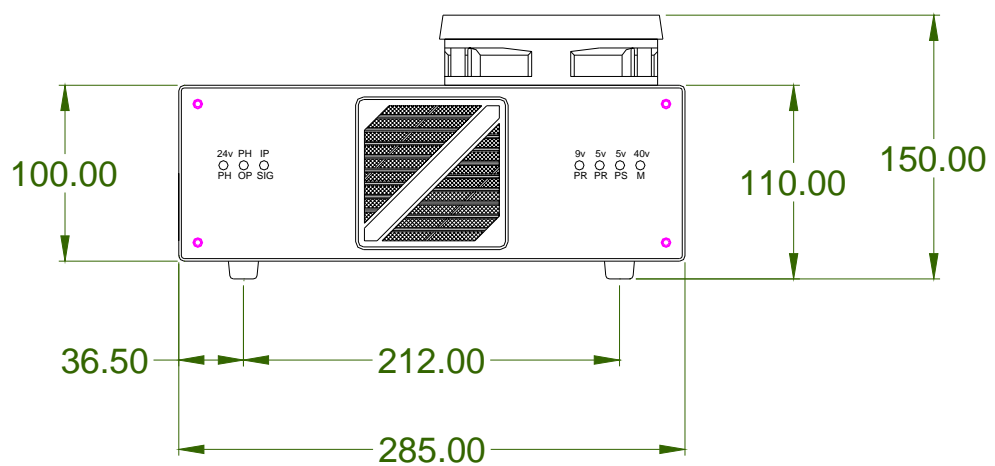

COMPUTER CONNECTION LEADS

COMPUTER TO PRINTER 9 WAY "D" CONNECTOR (COM1)

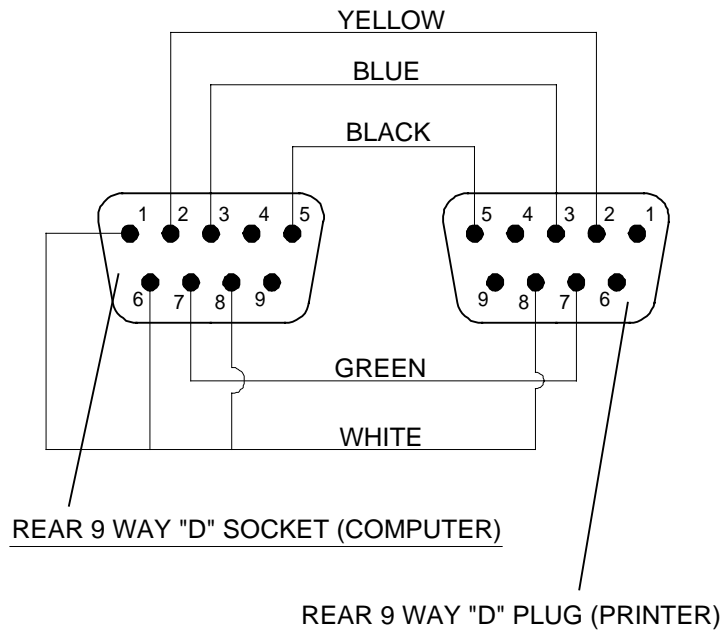

Re – Order: PART No. LEA 755021

AIRBORNE NOISE EMISSIONS.

Comprehensive tests have been carried out with the Thermocode fitted in a standard printer frame and mounted onto a typical label applicator. Measurements were taken at 1.6 metres above floor level and approximately 1 metre away from the printer in all directions.

The measuring equipment used for conducting the tests was a Digital Sound Level Meter, type d-1405E supplied by Lucas CEL. Before the tests were carried out the instrument was calibrated and fitted with a foam windshield.

The noise levels shown below are the equivalent continuous "A-weighted" sound pressure levels in decibels "dB(A)".

PRINTER STATUS	NOISE LEVEL - DECIBELS (dB)
Awaiting Print signal	0
Continuously printing	66

OPEN DATE GROUP COMPANIES**FRANCE****Open Date France**

Z.I. D'Attichy,
No.8, voie industrielle
60350 Attichy,

Local Tel: - 03 44 42 94 43

Local Fax: - 03 44 42 17 17

International Tel: - (0033) 3 44.42.94.43

International Fax: - (0033) 3 44.42.17.17

GERMANY**Open Date Kennzeichnungssysteme GmbH**

Mittlere Stämmig 4
D-97292 Üttingen.

Local Tel: - 09369 9824 0

Local Fax: - 09369 9824 24

International Tel: - (0049) 9369 9824 0

International Fax: - (0049) 9369 9824 24

U.S.A**Open Date Systems Inc.**

Springfield Road,
PO Box 538,
Georges Mills,
NH 03751-0538.

Local Tel: - 603 763 3444

Local Fax: - 603 763 4222

International Tel: - (001) 603 763 3444

International Fax: - (001) 603 763 4222