

NOTE  
CUT HEAT SHRINK (HSK 507407) TO 50.00mm LONG  
AND FIT HEAT SHRINK AS SHOWN IN VIEW A - A

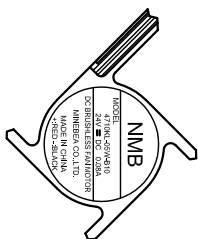

MANUFACTURER LABEL

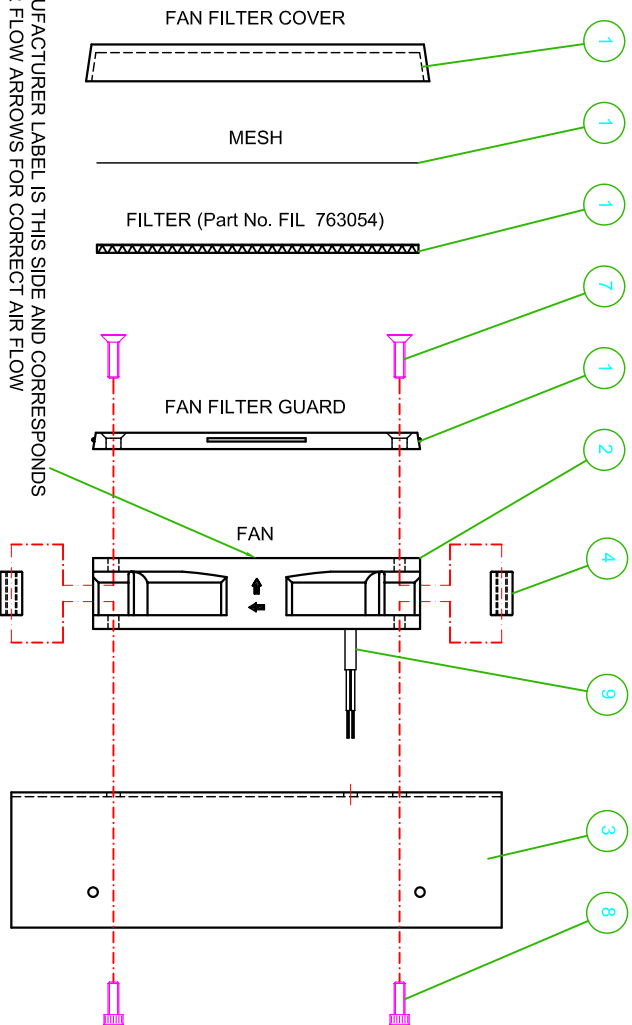

ENSURE MANUFACTURER LABEL IS THIS SIDE AND CORRESPONDS  
WITH THE AIR FLOW ARROWS FOR CORRECT AIR FLOW

| Ref. Prefix | Part No.    | Description                  | Iss. | Qty | Source       |
|-------------|-------------|------------------------------|------|-----|--------------|
| 1           | FIL 763053  | Fan Filter Unit              | 1    | 1   | Purchased    |
| 2           | FAN 763055  | Fan                          | 1    | 1   | Purchased    |
| 3           | UPI 763047  | Upiece Top Cover             | 1    | 1   | Manufactured |
| 4           | SPA 763058  | Spacer Standard Power Supply | 2    | 4   | Manufactured |
| 5           | ELE 507300  | Cable Tie                    | n/a  | 1   | Purchased    |
| 6           | BAS 507317  | Cable Tie Base               | n/a  | 1   | Purchased    |
| 7           | FAS M4CSS16 | Countersunk Set Screw        | n/a  | 4   | Purchased    |
| 8           | FAS M4SCS12 | Socket Cap Screw             | n/a  | 4   | Purchased    |
| 9           | HSK 507407  | Heat Shrink                  | n/a  | 1   | Purchased    |
| 10          |             |                              |      |     |              |

|         |        |           |         |
|---------|--------|-----------|---------|
| MOD No. | Date:- | Used On:- | Issue:- |
|         |        |           | 4       |

|       |        |       |                        |        |          |
|-------|--------|-------|------------------------|--------|----------|
| Sheet | 1 of 1 | Title | Assembly Top Cover Fan | Prefix | Part No. |
|       |        |       |                        | ASY    | 763057   |



VIEW A - A

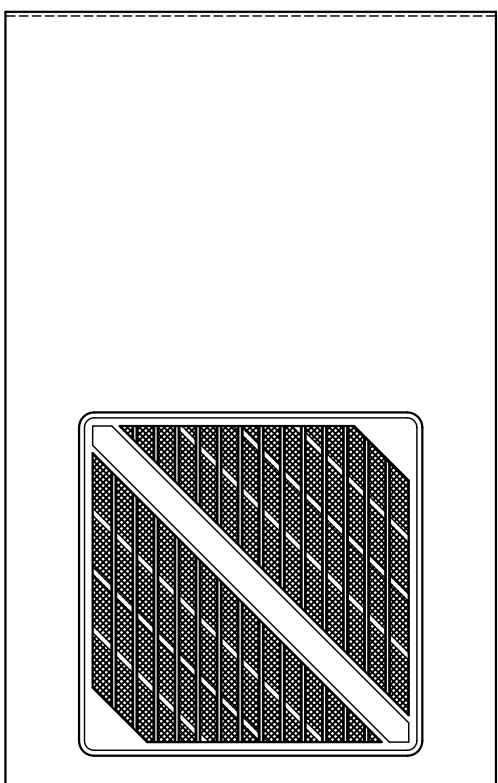

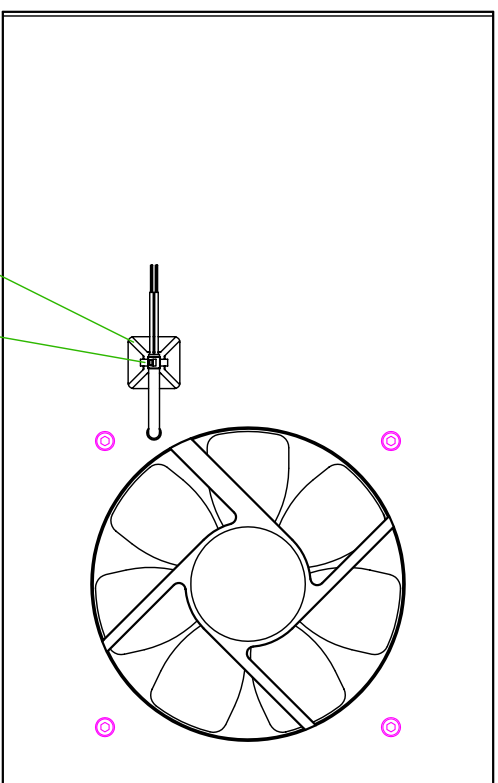
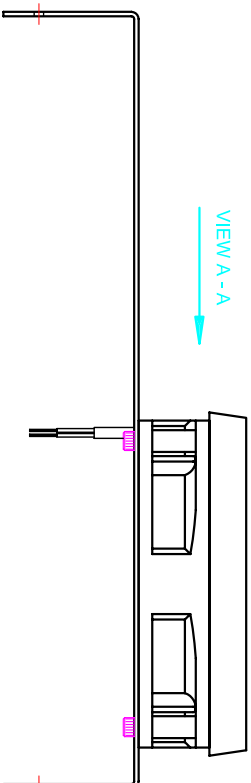
|             |      |             |                |          |                         |
|-------------|------|-------------|----------------|----------|-------------------------|
| ISSUE       | 4    | DATE        | 28 MAY 2004    | REVISION | N/A                     |
| REVISION    |      | DESCRIPTION | SEE PARTS LIST |          |                         |
| DATE        | NONE | SCALE       | 1:1            |          |                         |
| DESIGNED BY | OWNP | DESIGNED    |                |          |                         |
| DATE        |      | SCALE       | 1:1            |          |                         |
|             |      |             |                | DESIGNED | REDESIGNED              |
|             |      |             |                | OWNP     | OWNP                    |
|             |      |             |                |          | ASSEMBLY TOP COVER FAN  |
|             |      |             |                |          | OPEN DATE EQUIPMENT LTD |
|             |      |             |                |          | ASY 763057              |