

THERMOCODE SERIES 2 (All Models) Interconnect Board Wiring Details. (sheet 2)

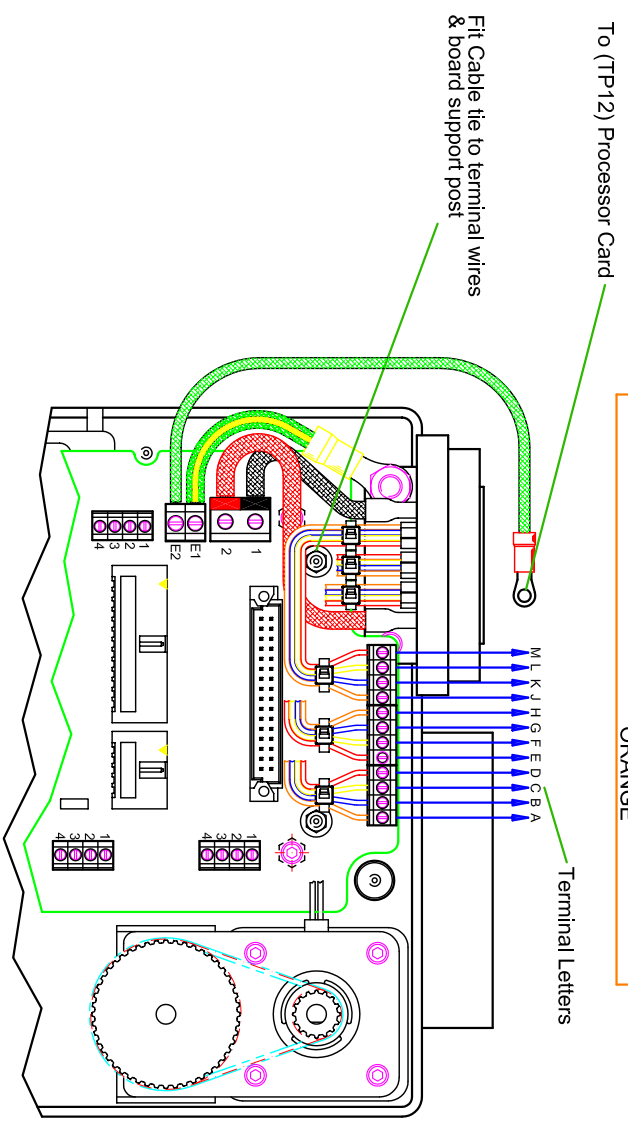
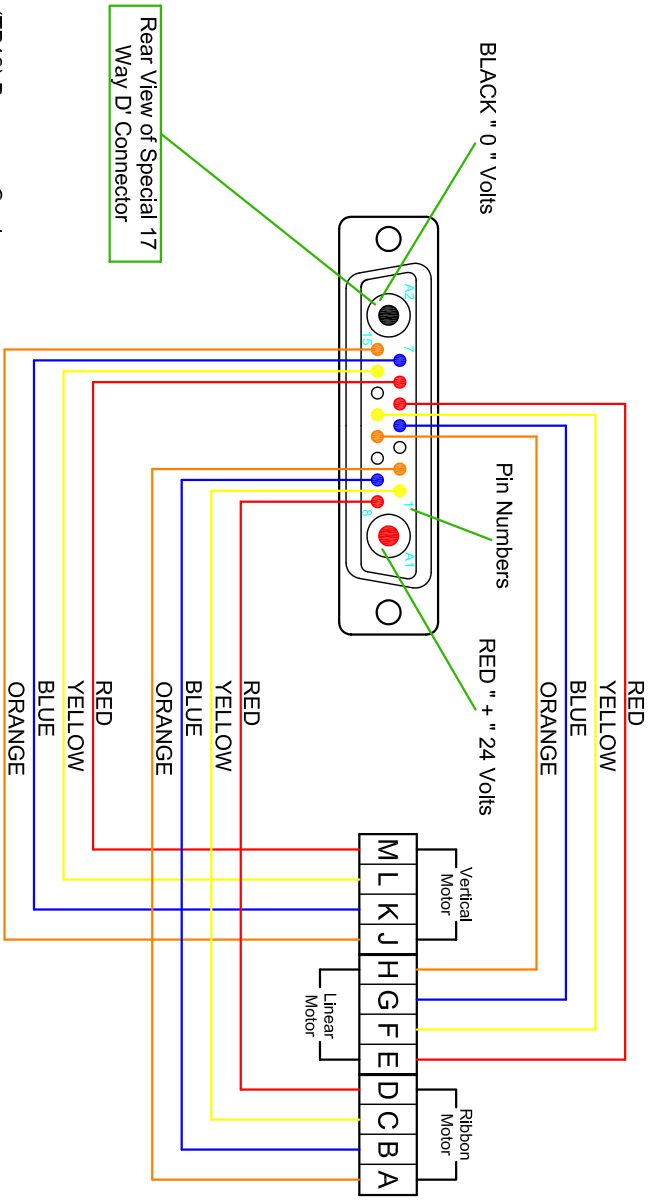

D' Connector Pin Numbers	Terminal Block Letter Ref.	Wire Colour
8	D	Red
1	C	Yellow
9	B	Blue
2	A	Orange
11	H	Orange
4	G	Blue
12	F	Yellow
5	E	Red
6	M	Red
14	L	Yellow
7	K	Blue
15	J	Orange

NOTES.

1. Connect Wires as detailed above
Fitting wires around support post.
2. Fit Cable ties to each set of Motor wires as shown.
3. Fit Cable tie to terminal wires & board support post.
4. Connect the 24 Volt (Red & Black) wires to large terminal block as shown.
Terminal 1 = 0 volt (Black)
Terminal 2 = 24 Volt (Red)
5. Connect Printer Body Earth wire to Terminal E1.
6. Connect Processor Card (TP12) Earth wire to Terminal E2

ISSUE	DATE	REASON	N/A
2	07 JUN 2004		N/A
MATERIAL FINISH		SEE NOTE ABOVE	
DRAWN		NONE	
CWP		CHECKED	
SCALE		1 : 1	
DRAWING		OPEN DATE EQUIPMENT LTD	
PART NO		REF 767005	