

## INSTRUCTIONS (Using a 2.5mm Hexagon Key)

1. Remove Ribbon from Cassette.
2. Release "Lock Screw" by half a turn.
3. Screw in the "Adjustment Screw" until the "Brake Arm" is just clear of the "Stop Pin".
4. Rewind the "Adjustment Screw" until the "Brake Arm" is resting against the "Stop Pin".
5. Rewind the "Adjustment Screw" by an additional full turn.
6. Tighten the "Lock Screw".

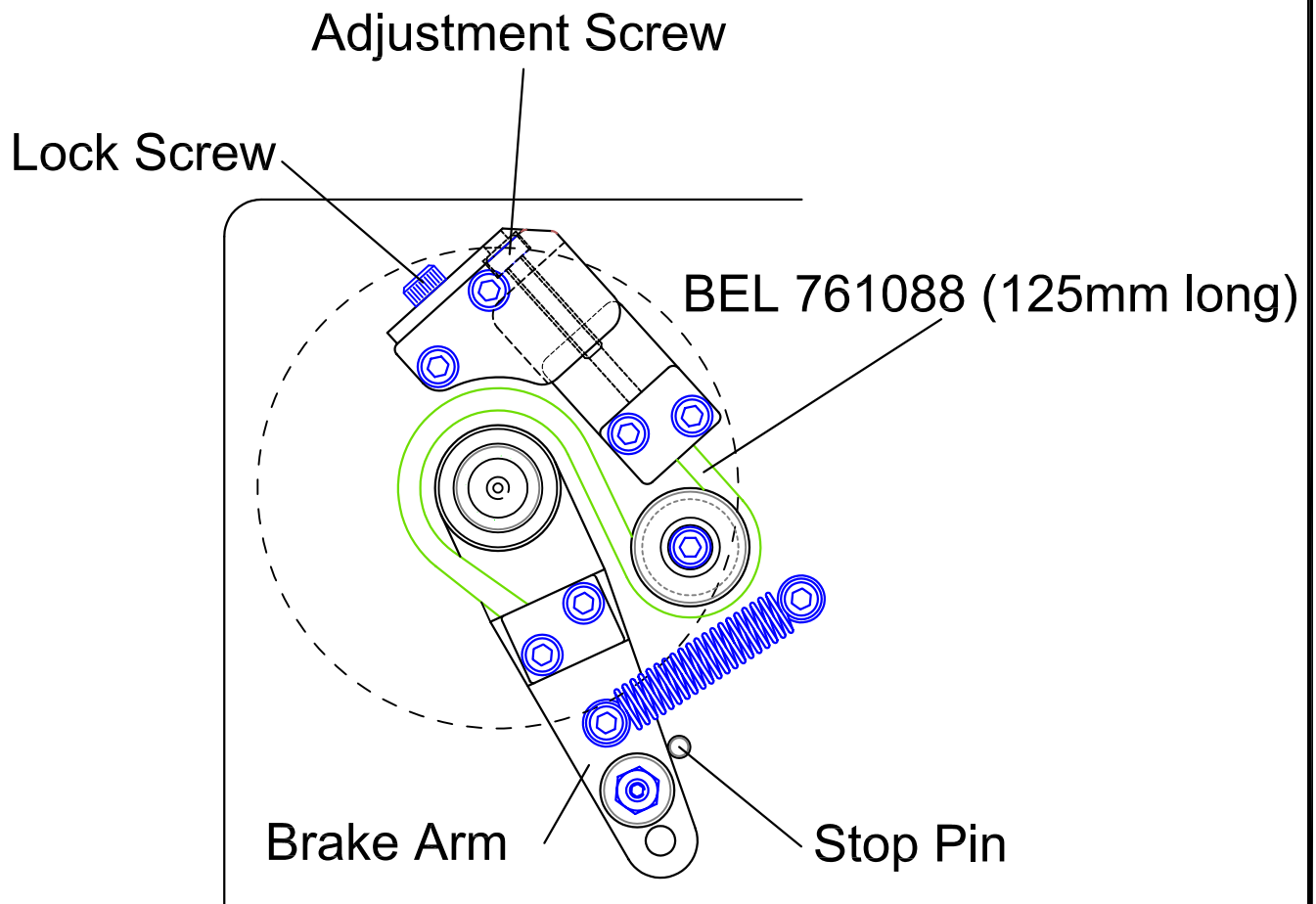

For Printer Models:- 53S, 53M, 53L, 107S, 107M, 107L

ISSUE	1	DATE	13/05/2003	TITLE	Band Brake Settings (Intermittent Printers)			
DRAWN	CC	CHECKED		SCALE	None	OPEN DATE EQUIPMENT LTD	PART NO	REF 767082